

Model FDDPTC1-5.5 - FDDPTC2-5.5

- 2 Channel Combiner
- Constant Impedance Type
- FM Band 87.5-108 Mhz

A constant impedance combiner consists of two or more band pass filters, two 3dB couplers and a dummy load. One or more inputs is/are narrow band while the remaining input(s) can be broadband. Input impedance is not frequency dependent.

TYPICAL SPECIFICATIONS

Model	FDDPTC1-5.5 - FDDPTC2-5.5 – Type CONSTANT IMPEDANCE
Impedance	50 Ohm
Frequency Range	87.5+108 MHz
VSWR ±150 KHz	1.1:1 Max
Insertion Loss	at f_0 0.45 dB Max (Narrow Band Input) 0.1 dB Max (Broad Band Input)
Return Loss ±150 KHz	≤ -26 dB
Isolation ±1.2 MHz	NB to BB ≥ 30dB, BB to NB ≥ 40dB
No. of input	2 (NarrowBand+BroadBand)
No. of output	1
Connectors	Input 7/16" (FDDPDC1-5.5) Input 7/8" EIA (FDDPDC2-5.5) 7/8" EIA Output
Max Power	1000 W 2 Channels (FDDPDC1-5.5) 2000 W 2 Channels (FDDPDC2-5.5)
Temperature Range	-20°C ÷ +50°C
Color	Enamel gray ral 7001
Materials	Aluminium, silver brass, copper, PTFE, stainless steel, silver plated (min 12μ thickness)

- Distortion – Free
- Custom configuration available
- Low loss, high isolation
- Natural convection
- ▶ Optional group delay equalizer
- Input impedance not frequency dependent
- ▶ The frequency at the broadband input can be changed without returning the bandpass cavity filters

Dimensions	1300(Max size) x 780 x 480 mm (51.2(Max size) x 22.4 x 18.9 inch) (H x L x W)
Net Weight	≅ 70 Kg

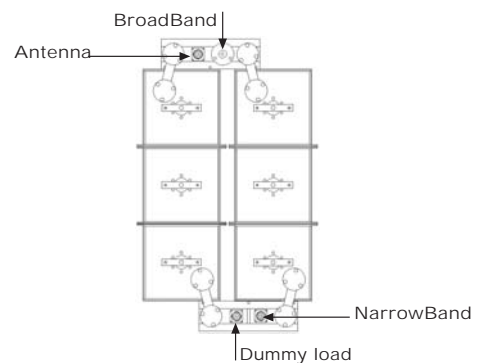
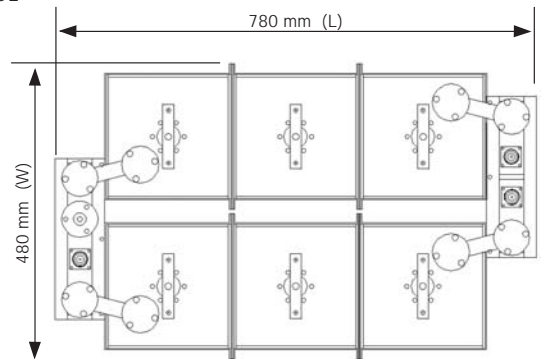

"These specifications are subject to change without notice"