

Compact Series

T800 / T1200 / T1500 / T1800 / T2000



1045 Tenth Avenue
San Diego, CA 92101
Tel: (619) 239-8462
Fax: (619) 239-8474
E-mail: support@bext.com
<http://www.bext.com>

Table of Contents

OVERVIEW	3
TECHNICAL CHARACTERISTICS	7
PRELIMINARY INSTRUCTIONS AND WARRANTY INFORMATION	8
OPERATIONAL CONTROLS	10
<i>Front panel description</i>	10
INSTALLATION	13
<i>INSTALLING THE TUBE</i>	13
<i>Rear panel description</i>	14
<i>MAIN POWER SUPPLY CONNECTION</i>	15
<i>FIRST STARTING</i>	15
<i>TUNING</i>	16
<i>DEGRADING FACTORS</i>	17
MAINTENANCE	18
<i>To open the top panel</i>	19
<i>Opened top view</i>	20
<i>To remove the front panel</i>	21
<i>To remove the rear panel</i>	22
<i>Left side panel removal (and air filter)</i>	23
<i>To open RF Amplifier Cavity</i>	24
<i>Removal of the rf compartment</i>	25
<i>Air flow protection setting</i>	26
SCHEMATICS :.....	27
<i>R.F. Schematic for 3CX1500A7 tube</i>	27
<i>R.F. Schematic for 3CX800A7 tube</i>	29
<i>Power supply and control schematic (single phase)</i>	31
<i>Power supply and control schematic (three-phase)</i>	33
<i>E20123 - Bias Board</i>	35
<i>E20126 - Front panel board</i>	37
<i>E20127 - Control board</i>	40
<i>E20128 - SCR board</i>	53
<i>E20129 - Output power measurement board</i>	55
<i>E20130 - Three phase rectifier board</i>	57
<i>E20137 - Single phase rectifier board</i>	59
<i>E20138 - Voltage divider board</i>	60
<i>E20139 - Interface board (optional)</i>	61

OVERVIEW

The final sections of the **Compact T-Series** amplifiers use a thermionic tube. The whole design is expressly optimized for frequency modulated signals in the 87.5 108 MHz band with standard ± 75 KHz deviation, **SCA** (Subsidiary Channel Authorization) and **RDS** (Radio Data System) signals.

On request a **63-77 MHz** FM band model is available.

Power output ratings vary according to the model from 750 W minimum, up to 2,000 W. Main power supply can be either single phase or three-phase. Refer to the following table for the proper model and output power correspondence.

MODEL	TUBE	POWER SUPPLY	OUTPUT POWER
T 800 - 1	3CX800A7	mono-phase	750 W
T 800 - 3	3CX800A7	three-phase: triangle or star	850 W
T 1200 - 1	3CX1500A7 (8877)	mono-phase	1,200 W
T 1200 - 3	3CX1500A7 (8877)	three-phase: triangle or star	1,200 W
T 1500 - 1	3CX1500A7 (8877)	mono-phase	1,500 W
T 1800 - 1	3CX1500A7 (8877)	mono-phase	1,800 W
T 2000 - 3	3CX1500A7 (8877)	three-phase: triangle or star	2,000 W

Table 1 - Compact T-Series - Available models and corresponding output power

The last configuration has taken all the benefits of a decade of continuous improvements. Most of these improvements have been made according to our customers' suggestions. The result of such experience is now bounded in one of the smallest Rack in its own category. Among the others, main characteristics may be summarised as follow:

- Reliability
- Quality
- Compactness
- Flexibility
- Safety
- Easy setting operations
- Easy maintenance operations
- Protection logic sophisticated and highly reliable
- Service electronics now totally immune from radiofrequency disturbs and high tension discharges

- Electronic start-up procedure, with time saving facility. In case of short power supply failure, the time saving facility skips all the start-up procedure
- Automatic reset after protection occurred
- Protection counter display
- Emergency shut down after eight automatic resets
- Microprocessor interface

Reliability

The protection system is the most sophisticated available in this category of equipment. The stabilisation of the tube filament bias is done in true RMS value, therefore granting a considerable improvement in the tube life, with maintenance costs reduction.

Quality

The transfer function of tuning circuitry has been expressly optimized for a low residual synchronous amplitude modulation, with low Q filters. The advantage of such improvement is especially evident when broadcasting also RDS and SCA signals, or with stereo coded audio.

Compactness

Compact T-Series amplifiers use a compact standard 19", 8 U Rack. This feature revealed extremely useful in saving space in the installation site. Besides Compact T-Series amplifiers are light and easy to move. These positive results have been obtained without sacrificing any essential feature, i.e. the equipment reliability, the sturdiness, the easy maintenance, etc.

Flexibility

Thanks to its modular design, upgrading a Compact T-Series amplifier is a breeze. You can decide to increase the power, change the main power supply from single phase to three-phase, or even select the desired output jack ("N", "LC", "7/16", "7/8") just during the installation.

Safety

We have added a complete safety protection system to the Compact T-Series amplifiers. The upper panel raising opens a microswitch, cutting immediately off the main power supply, if any. Moreover, dangerous points cannot be reached without previously, intentionally, shields disassembling.

Easy setting operations

The input circuit is broadband. The required frequency and loading matching tuning are made in the output circuit. The front panel controls allow these two operations in the entire 87.5 108 MHz band, without the need to disassemble the amplifier.

Easy maintenance operations

The modular design speeds up every operation, while the front panel indicators can supply all the information you may need.

Protections

- The protections now include the following signals:
- IG current exceeding the threshold
- IA current exceeding the threshold
- TEMPERATURE level exceeding the threshold
- S.W.R. level exceeding the threshold
- TUBE irregular polarisation
- FILAMENT VOLTAGE irregular
- Transformer TEMPERATURE level exceeding the threshold
- PANELS CLOSING AND/OR ANY ELECTRICAL CONNECTION irregular
- MAIN POWER SUPPLY overvoltage

Technical Characteristics

	T800-1	T800-3	T1200-1	T1200-3	T1500-1	T1800-1	T2000-3	
Single phase Power supply <i>absorption in Ampère (220V)</i>	400 W	750 W	600 W	600 W	750 W	1,000 W	1,000 W	
Star type three phase supply	110/220 V 50/60 Hz	110/220 V 50/60 Hz	110/220 V 50/60 Hz	110/220 V 50/60 Hz	110/220 V 50/60 Hz	110/220 V 50/60 Hz	110/220 V 50/60 Hz	
absorption in Ampère	6 A	10 A	6.8 A	13.6 A	10.5 A	11.8 A	21.3 A	
Triangle type three phase supply	3x380 V + N; 3x410 V + N	3x380 V + N; 3x410 V + N	3x380 V + N; 3x410 V + N	3x380 V + N; 3x410 V + N	3x380 V + N; 3x410 V + N	3x380 V + N; 3x410 V + N	3x380 V + N; 3x410 V + N	
absorption in Ampère	50 / 60 Hz	50 / 60 Hz	50 / 60 Hz	50 / 60 Hz	50 / 60 Hz	50 / 60 Hz	50 / 60 Hz	
General power consumption	1.8; 1.8; 2.7; 2.7; 2.3; 0.5	2.7; 2.7; 3.2; 0.5	2.1; 2.1; 3.4; 3.4; 2.7; 0.6	4.1; 0.7	3.6; 4.2; 5.9; 6.6; 4.2	3.6; 4.2; 5.9; 6.6; 4.2	3.6; 4.2; 5.9; 6.6; 4.2	
Power factor	cosφ = 0.9	cosφ = 0.9	cosφ = 0.9	cosφ = 0.9	cosφ = 0.9	cosφ = 0.9	cosφ = 0.9	
Thermionic tube type	EIMAC 3CX800A7	EIMAC 3CX800A7	EIMAC 3CX1500A7 (8877); 3CPX1500A7	EIMAC 3CX1500A7 (8877); 3CPX1500A7	EIMAC 3CX1500A7 (8877); 3CPX1500A7	EIMAC 3CX1500A7 (8877); 3CPX1500A7	EIMAC 3CX1500A7 (8877); 3CPX1500A7	
Expected tube lifetime	15,000 Hrs.	10,000 Hrs.	22,000 Hrs.	18,000 Hrs.	20,000 Hrs.	17,000 Hrs.	17,000 Hrs.	
Min. granted output power	750 W	850 W	1,200 W	1,200 W	1,500 W	1,800 W	2,000 W	
Power gain	> 15 dB	> 15 dB	> 16 dB	> 16 dB	> 15 dB	> 14 dB	> 15 dB	
Required driving power	11 W	24 W	15 W	28 W	18 W	44 W	50 W	
IN and OUT connections	IN: 50Ω - "N" jack OUT: 50Ω - lc, 7/8, 7/16	IN: 50Ω - "N" jack OUT: 50Ω - lc, 7/8, 7/16	IN: 50Ω - "N" jack OUT: 50Ω - lc, 7/8, 7/16	IN: 50Ω - "N" jack OUT: 50Ω - lc, 7/8, 7/16	IN: 50Ω - "N" jack OUT: 50Ω - lc, 7/8, 7/16	IN: 50Ω - "N" jack OUT: 50Ω - lc, 7/8, 7/16	IN: 50Ω - "N" jack OUT: 50Ω - lc, 7/8, 7/16	IN: 50Ω - "N" jack OUT: 50Ω - lc, 7/8, 7/16
Operating temp. range	+ 0 / + 45 °C	+ 0 / + 45 °C	+ 0 / + 45 °C	+ 0 / + 45 °C	+ 0 / + 45 °C	+ 0 / + 45 °C	+ 0 / + 45 °C	
Ambient humidity	90 %	90 %	90 %	90 %	90 %	90 %	90 %	
Installation altitude	3,000 above sea level	3,000 above sea level	2,500 above sea level	2,500 above sea level	2,500 above sea level	2,500 above sea level	2,500 above sea level	
Max reflected power	100 W	100 W	100 W	100 W	80 W	60 W	60 W	
R.F. harmonic rejection	- 77 dBc	- 77 dBc	- 77 dBc	- 77 dBc	- 77 dBc	- 77 dBc	- 77 dBc	
Synchronous A.M.	0.07 dBc	0.07 dBc	0.07 dBc	0.07 dBc	0.07 dBc	0.07 dBc	0.07 dBc	
Anode current Ia	240 mA	430 mA	360 mA	640 mA	360 mA	750 mA	450 mA	
Grid current Ig	500 mA	500 mA	650 mA	650 mA	850 mA	950 mA	990 mA	
R.F. cavity temperature	27 mA	27 mA	80 mA	80 mA	80 mA	80 mA	80 mA	
Filament voltage	65 °C	65 °C	65 °C	65 °C	65 °C	70 °C	75 °C	
High voltage	90 °C	90 °C	90 °C	90 °C	90 °C	90 °C	85 °C	
Bias voltage	Vfil = 13-14 V	Vfil = 13-14 V	Vfil = 4.75-5.15 V	Vfil = 4.75-5.15 V	Vfil = 4.75-5.15 V	Vfil = 4.75-5.15 V	Vfil = 4.75-5.15 V	
Anode efficiency	VHT = 3,200 V Vbias = 17-19 V 50 %	VHT = 3,300 V Vbias = 17-19 V 50 %	VHT = 3,400 V Vbias = 18-19.5 V 48 %	VHT = 3,400 V Vbias = 18-19.5 V 48 %	VHT = 3,700 V Vbias = 18.5-20 V 50 %	VHT = 3,700 V Vbias = 18.5-20 V 55 %	VHT = 3,800 V Vbias = 19-20 V 55 %	

PRELIMINARY INSTRUCTIONS AND WARRANTY INFORMATION



Please observe safety precautions when handling this unit. This equipment contains dangerous currents and voltages.



This manual is written as a general guide for those having previous knowledge and experience with these kinds of equipment. It is not intended to contain a complete statement of all safety precautions which should be observed by personnel in using this or other electronic equipment.



BEXT Inc. does not assume responsibility for injury or damage resulting from improper procedures or practices of untrained/unqualified personnel in the handling of this unit.



Please observe all local codes and fire protection standards in the operation of this unit.



CAUTION : Always disconnect power before opening covers or removing any part of this unit. Use appropriate grounding procedures to short out capacitors and high voltage points before servicing.

- * Any damage to the goods must be reported to the carrier in writing on the shipment receipt. Any discrepancy/damage discovered subsequent to delivery shall be reported to BEXT Inc. within five days of its receipt.
- * The company warrants this product to be in working order for one year period from the shipment date. If this product fails to be in working order during the one year warranty period, the company will, with its option, repair or replace the product at no charge except as set forth below.
- * To obtain warranty service described herein, deliver the product along with proof of purchase date. The owner agrees to insure the product and assume the risk of damage or loss in transit, to pay in advance all shipping charges, and to use the original shipping container (or the equivalent).
- * BEXT extends to the end-user/purchaser all original manufacturers warranties which are transferable and all claims are to be made directly to BEXT Inc.
- * All manufacturers warranties will be supported by BEXT to ensure precise and speedy service where possible.
- * BEXT shall not be liable for any damages of whatsoever nature arising out of , or in connection with, the product or its use thereof.
- * BEXT warranty shall not include :
 - reshipment of the unit to BEXT for repair purposes ;
 - any unauthorised repairs/modifications ;
 - incidental/consequential damages as a result of any defect ;
 - nominal nonincidental defects ;
 - reshipment costs or insurance of the unit or replacement units/parts.

- * To claim your rights under this warranty :
 - A. Contact the dealer or distributor from whom this product was purchased. Describe the problem and ask if he has an easy solution. Dealers and distributors are supplied with information on problems which may occur and usually can repair the unit more quickly than by going directly to the factory. It is also often true that errors in installation or use will be discovered by your dealer.
 - B. If your dealer cannot help, contact BEXT at address below and explain the problem. If it is determined that the unit needs to be returned to the factory, BEXT will mail you a return authorisation with instructions.
 - C. When you receive the authorisation, you can return the unit. Pack the unit carefully for shipment. Preferably use the original packing materials and assume that the shipping carton will be dropped several times during the transportation process. The customer assumes the risk of loss until the package is received by BEXT so we advise you to take the insurance for the full replacement value of the unit. Ship the unit PREPAID to the address specified on the return authorisation. **DO NOT RETURN UNITS WITHOUT A RETURN AUTHORIZATION, AS THEY WILL NOT BE ACCEPTED.** Be sure to enclose a written descriptive statement of the problem experienced and a copy of your original invoice establishing the starting date of the warranty.
- * Replacement and warranty parts may be ordered from the following address. Be sure to include equipment model with serial number, part description and if it is possible, part code.



1045 Tenth Avenue
San Diego, CA 92101
Tel: (619) 239-8462
Fax: (619) 239-8474
E-mail: support@bext.com
<http://www.bext.com>

OPERATIONAL CONTROLS

The external layout efficiently supports the work of the operator by providing all the measures and controls really necessary for a safe system operation monitoring. All you need can be found at a glance.

Front panel description

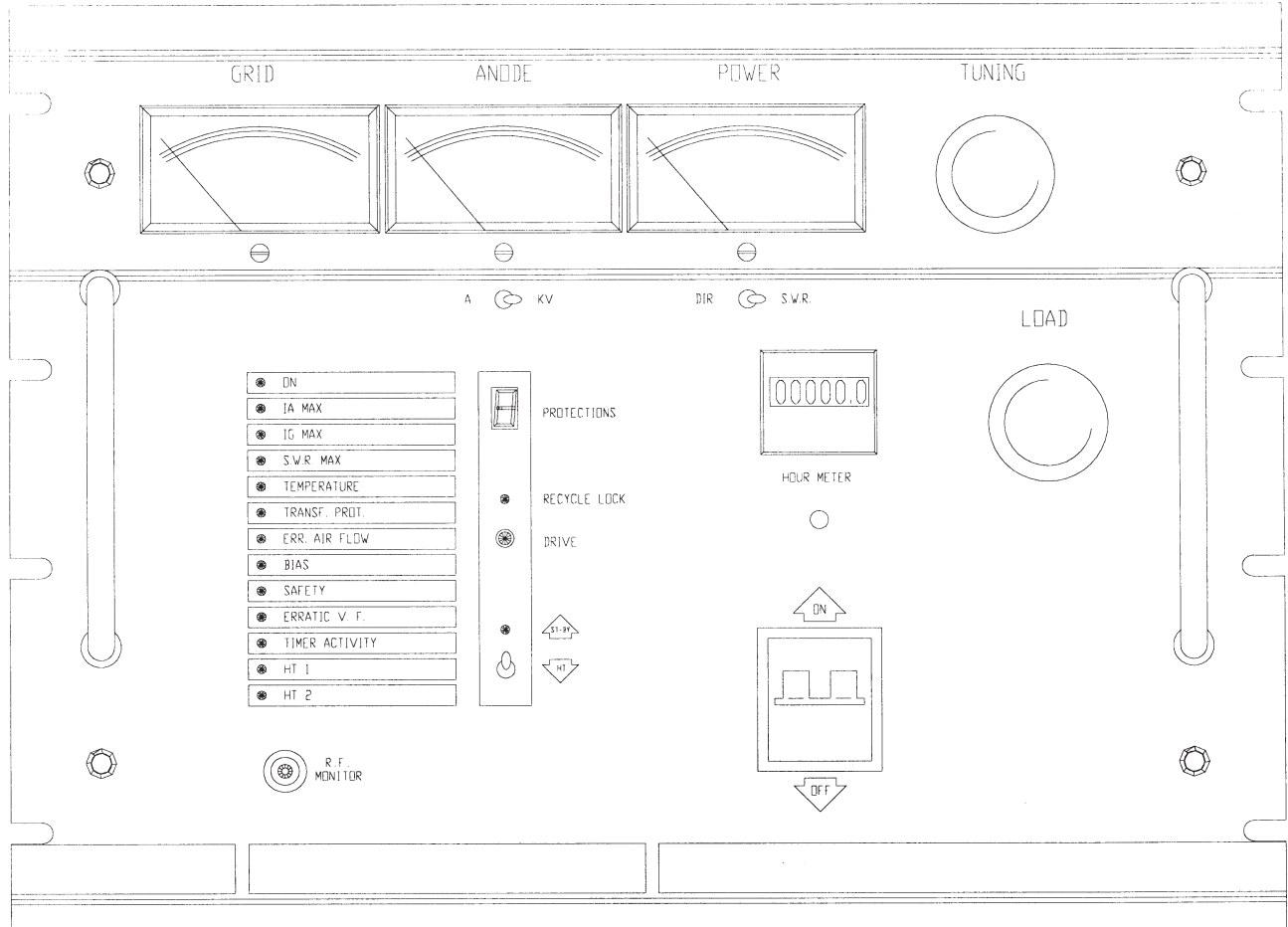

GRID Control grid current metre (in mA).

ANODE Anode current metre (in mA) or anode voltage. The A/KV microswitch below the instrument commutes the two measures.

POWER Direct or reflected power meter (in W). The DIR/SWR microswitch below the instrument commutes the two measures.

TUNING Rotating knob for the output frequency tuning. It varies the anode circuit resonance frequency in the RF cavity. Rotating the knob clockwise, lower frequency tuning will be achieved. Rotating the knob counterclockwise, higher frequency tuning will be achieved. Finely rotate the knob to get the maximum output power.

This operation shall be made every time a load matching setting is performed ("LOAD" knob, see following)

LOAD Rotating knob for the optimum output impedance load matching. Rotating the knob clockwise, the anode circuit impedance increases, the anode current I_A decreases and the IG control grid current increases. Rotating the knob counterclockwise, the anode circuit impedance decreases, the anode current increases, and the IG control grid current decreases.

Every time the output circuit impedance is changed, you shall verify the frequency tuning, and do it again in case it has changed (see TUNING).

HOURS COUNTER This electromechanical counter is connected to the main power switch, thus enabling a precise tube lifetime monitoring.

MAIN POWER SUPPLY SWITCH For maximum safety and protection, it works on all phases of the main power supply.

SIGNALLING LAMPS COLUMN Each lamp stays on or off according to the actual state of the amplifier. From the top:

- ◆ **ON** When this lamp is lit, power is supplied to the amplifier.
- ◆ **IA MAX** When this lamp is lit the anode current has exceeded the threshold value.
As a consequence, the exciter power supply is cut off. This protection is subjected to the automatic reset. After the eighth intervention occurred, the amplifier stays in the OFF state, with the LOCK lamp on.
- ◆ **S.W.R. MAX** When this lamp is lit the reflected power has exceeded the threshold value.
As a consequence, the exciter power supply and the anode bias are cut off. This protection is subjected to the automatic reset. After the eighth intervention occurred, the amplifier stays in the OFF state, with the LOCK lamp on.
- ◆ **TEMPERATURE** When this lamp is lit the temperature has exceeded the anode circuit threshold value.
As a consequence, the exciter power supply and the anode bias are cut off. This protection is subjected to the automatic reset. After the eighth intervention occurred, the amplifier stays in the OFF state, with the LOCK lamp on.
- ◆ **TRANSF.PROT.** When this lamp is lit, the anodic power supply temperature has exceeded the threshold.
As a consequence, the exciter power supply and the anode bias are cut off. This protection is subjected to the automatic reset. This protection however does not affect the protection counter.
- ◆ **ERR.AIR FLOW** This lamp turns on when the air flow pressure inside the tube cooling system is not sufficient for an effective air ventilation.
As a consequence, the exciter power supply, the anode bias and the filament supply are cut off. The "ERRATIC V.F." signalling will then be activated (see further on). This protection however does not affect the protection counter.
- ◆ **BIAS** This lamp turns on when the tube cathode / control grid bias is not correct.
As a consequence, the exciter power supply and the anode bias are cut off. Since this protection occurs only in case of serious failures, it is not subjected to the automatic reset. Before resetting this protection, the operator shall first make sure to remove the trouble.

- ◆ **SAFETY** This lamp turns on either when a panel in the Rack is not properly closed or in presence of a loose connection. Either case may in fact represent a serious risk for the operator and/or for the equipment.

As a consequence, the exciter power supply and the anode bias and the filament supply are cut off. If the intervention lasts more than one second, the protection logic starts again the start-up procedure. The "TIMER ACTIVITY" lamp (see below) will then stay on. This protection however does not affect the protection counter.

- ◆ **TIMER ACTIVITY** When this lamp is lit the built in timer is doing the start-up procedure. This includes the tube cathode heating and the residual humidity drying. After the start-up procedure is over, the timer circuitry enables the anodic supply and gives the exciter power supply consent. The start-up procedure lasts for almost 5 minutes (it takes 320 340 seconds since the filament voltage is stabilized).
- ◆ **HT1** This lamp turns on when the timer has completed the gradual anode power supply first step. After one second HT2 (see below) turns on, thus concluding the cycle.
- ◆ **HT2** This lamp turns on when the timer has completed the gradual anode power supply second step, and your COMPACT amplifier is ready for operating.

PROTECTION COUNTER It shows the number of protections occurred concerning the following monitored measures: IA MAX, IG MAX, S.W.R. MAX, TEMP. MAX.

FURTHER CONTROLS SET From the top:

- ◆ **RECYCLE LOCK** This lamp turns on when the automatic reset, related to a specific measure, has tried eight times to reset the equipment.
As a consequence, the exciter power supply and the anode bias are cut off. One of the described lamps will consequently be lit, showing the failure. Here manual resetting will be necessary, pushing the DRIVE push-button (see below).
- ◆ **DRIVE** Pressing this push-button will result in a lock condition resetting and in the corresponding protection counter resetting.
- ◆ **STAND-BY** This lamp turns on when the operator has disabled the anodic voltage and the exciter power supply.
- ◆ **STAND-BY / HT** This two-way-switch turns ON/OFF the amplifier operating condition.

INSTALLATION



WARNING! Compact T-Series amplifiers comply with the international safety FCC, CCIR and IEC rules. Nevertheless, they are RF power amplifiers, and they must be installed, operated and maintained only by qualified personnel.



WARNING! Before starting the installation procedure, make sure that the power supply rating of your Compact T-Series amplifier corresponds to that in use in your own country. If you are not sure of the type of power available, consult your local dealer or the power company.

- ◆ Before attempting any further action, check the packing integrity.
- ◆ Unpack your Compact T-Series unit and check for missing items.
- ◆ Remove all unnecessary tools and packing pieces and clean the installation site. Make sure to have all you will need for the installation close and easy to reach.
- ◆ Avoid excessive humid or dusty places.
- ◆ Never install your transmitter near water or any other fluid spilling.
- ◆ If an extension cable will be used, make sure to check its power rating.
- ◆ The amplifier unit and the tube are coming into two different packs. Unpack the tube and insert it as described further on.
- ◆ Connect the coaxial cable from the exciter to the RF IN jack located on the rear panel.
- ◆ Connect the coaxial cable to the antenna load or to further amplification stages, to the RF OUT jack located on the rear panel.
- ◆ If your Compact T-Series unit needs a three-phase power supply, check that the neutral-phase potential does not exceed 35+40 V.
- ◆ Plug the exciter main power cord to the AUX SUPPLY plug in located on the rear panel.
- ◆ Plug the amplifier main power cord to the MAIN SUPPLY plug in located on the rear panel.

INSTALLING THE TUBE

The amplifier tube comes in separate packing. The tube shall be inserted in its socket through the cooling air van. To get inside please follow the procedure described in the maintenance chapter. Place the tube onto its socket and press gently but firmly until the tube results completely inserted.

Rear panel description

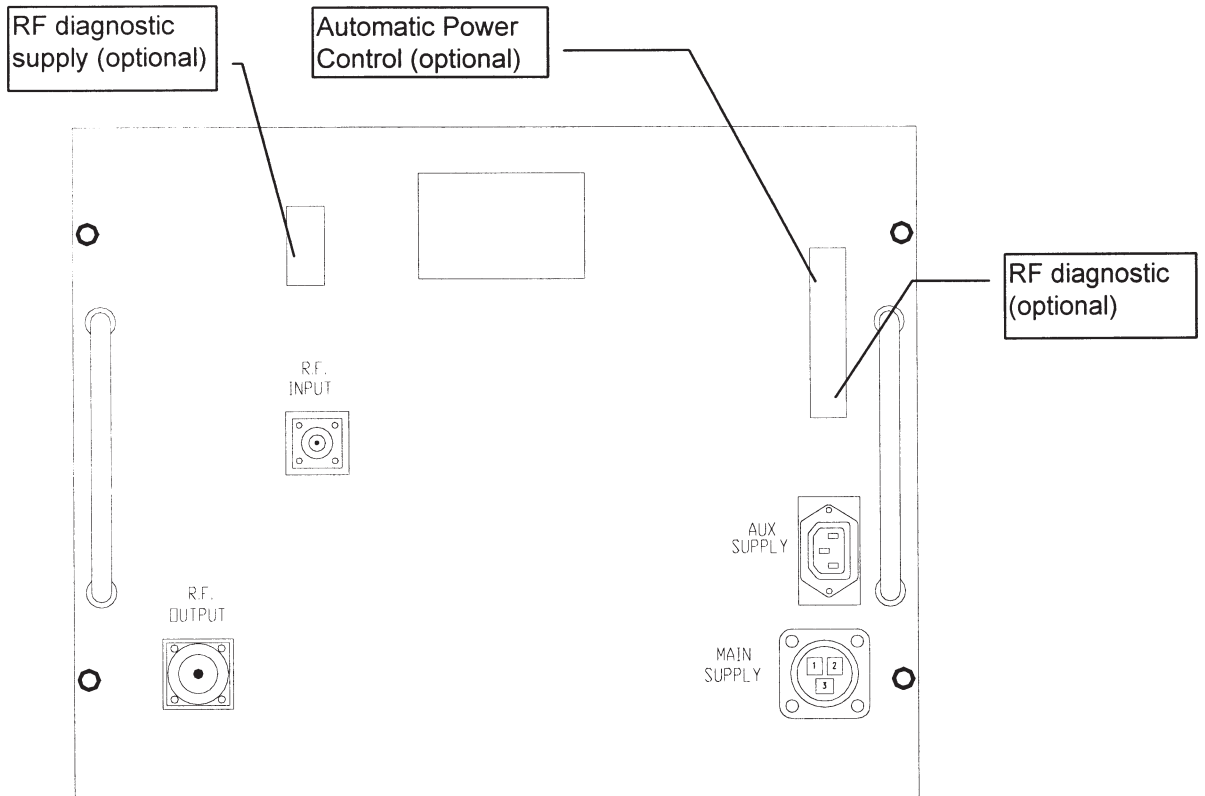

SINGLE PHASE MAIN SUPPLY

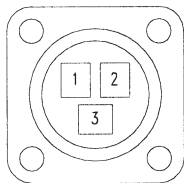

- 1= LINE IN
- 2= LINE IN
- 3= GROUND

THREE PHASES MAIN SUPPLY

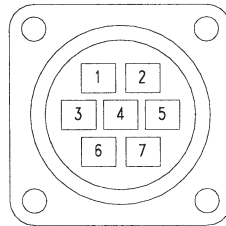

- 2= R
- 5= S
- 7= T
- 3= GROUND
- 4= NEUTRAL

AUX SUPPLY

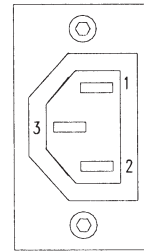

- 1= LINE OUT
- 2= LINE OUT
- 3= GROUND

MAIN POWER SUPPLY CONNECTION

Compact T-Series units have been designed to ensure safety installation and operation. Nevertheless, they are power amplifier and they can represent a potential risk if not correctly handled. At this step of the installation procedure, make sure to provide an efficient grounding for the amplifier rack. The grounding cable section shall be at least 6 mm².

The rear panel is provided with a V.D.F. standard plug (AUX SUPPLY) for the exciter and/or auxiliary equipment power supply. Make sure to connect the exciter power supply only to the amplifier AUX SUPPLY.

FIRST STARTING



WARNING! Before switching on the power amplifier, make sure that the exciter is not supplying any output power.

- ◆ Make sure your Compact T-Series amplifier is in stand-by position. When the main power switch is set to ON, the following actions should happen:
- ◆ A first transition step of 1 second: many signalling lamps may be on.
- ◆ A second step with the following lamps on:
 - > **ON**
 - > **STAND-BY**
 - > **ERRATIC AIR FLOW** will stay on for 3 seconds
 - > **ERRATIC V.F.** will stay on for 10 seconds
 - > **TIMER ACTIVITY** will stay on for 5 minutes
- ◆ After 320/340 seconds the protection logic ends the tube preheating cycle. The **TIMER ACTIVITY** lamp will consequently switch off and the amplifier will be ready for operations.
- ◆ Leave the equipment in this standby condition for almost one hour, in the following cases:
 - i. During first installation;
 - ii. After long inactivity periods;
 - iii. Every time the RF cavity has been involved in maintenance procedure.

TUNING

When the purchase order does not say the required operating frequency, the default manufacturer's setting is 98 MHz. Follow the following steps to tune your Compact T-Series amplifier on a different operating frequency.

- Make sure a 50-ohm load has been connected to the output jack. It can be either a dummy load or the antenna load.
- Make sure the exciter is powered by the amplifier.
- Make sure to put the following switches in the described position:
 - ⇒ Exciter output power minimum output power
 - ⇒ Amplifier main power ON position (ON green light on)
 - ⇒ STAND-BY / HT STAND-BY position (STAND-BY red light on)
 - ⇒ A / KV KV position
 - ⇒ OUT / S.W.R. OUT position
- When the TIMER ON lamp dims, the amplifier is ready for operations. Put the STAND-BY / HT switch to the HT position. HT1 green light will light and after 1-2 seconds also the HT2 light will stay on. This time shift is a consequence of the soft start procedure.
- Put now the KV/A switch in the A position
- Make sure again that the exciter is set for the minimum output power
- Put on the exciter and wait for the PLL locking
- Slowly increase the output power from the exciter, until the anodic current metre display a 100 mA value
- Make sure the switch DIR / SWR is in the DIR position
- Rotate now the TUNING knob to get the maximum power output value on the POWER instrument on the front panel
- Rotate now the LOAD knob to get the maximum power output value with the proper current values on the ANODE and GRID instruments on the front panel
- During LOAD knob operation, the output tuning gets out of setting. Any LOAD operation shall therefore be followed by a consequent TUNING knob adjustment.
- Let the amplifier operating for several minutes in this condition
 - During tube replacement operations, inner discharges may occur. These disappear after few minutes' operation. Therefore, is better to have the amplifier working at reduced power for the first minutes.
- Slowly increase then the exciter output power, until the output power reaches the half nominal power. In case of new tube installation, let the amplifier operating at this power for almost one hour.
- Slowly increase now the exciter output power, continuously checking that the anode and grid currents remain into the prescribed ranges (refer to next table). In case operate the LOAD knob to get the proper values.

Note ! Remember that the last action shall anyway be the TUNING operation, performed to get the maximum output power.

Model	IG (mA)	IA (mA)	P IN (W)	P OUT (W)
T 800	15 ÷ 20	380 ÷ 420	18 ÷ 24	800
T 1200	20 ÷ 30	550 ÷ 650	21 ÷ 28	1'200
T 1500	20 ÷ 30	650 ÷ 850	30 ÷ 40	1'500
T 1800	25 ÷ 35	800 ÷ 950	36 ÷ 50	1'800
T 2000	25 ÷ 35	870 ÷ 990	40 ÷ 60	2'000

- NOTE! Sometimes a more accurate analysis with a spectrum analyser must be preferred.

DEGRADING FACTORS

The values shown in the previous table refer to nominal power supply. No appreciable degradation will be measured for power supply decrease lower than 7%. In case the power supply reduction reaches 10/15% of its nominal value, the corresponding output power will result reduced of a 15/20%. For 15/20% reduction in the power supply, the output power will be reduced by a considerable 25/35%.

MAINTENANCE

A well scheduled maintenance activity will greatly improve your amplifier performances and life. Before attempting any disassembling operation, make sure to read and understand the following instructions:

- ◇ Unplug the main power supply, and all the auxiliary supplies from the wall outlet
- ◇ Disconnect the antenna load and any further connection with other equipment
- ◇ Make sure that a proper chassis grounding has been provided
- ◇ Soon after the top panel has been removed, make sure to ground the high voltage anodic supply



ALWAYS REMEMBER TO REMOVE THE HIGH VOLTAGE ANODIC SUPPLY BEFORE CLOSING THE TOP COVER.

Minimum intervention scheduling

Period	Description
At any tube replacement	Accurate dust cleaning Accurate electrical connections blocking
Every six months	Air filter replacement Reduce this interval in case of extremely dusty places
Five years	High voltage condensers replacement
Ten years	High voltage cables replacements Electromechanical switch replacement (relay, switches, etc.)
After a violent storm	Accurate check of the line overvoltage discharges

To open the top panel

For amplifier inside access, remove only the two screws close to the right edge of the top cover. Use a 3mm hex wrench.

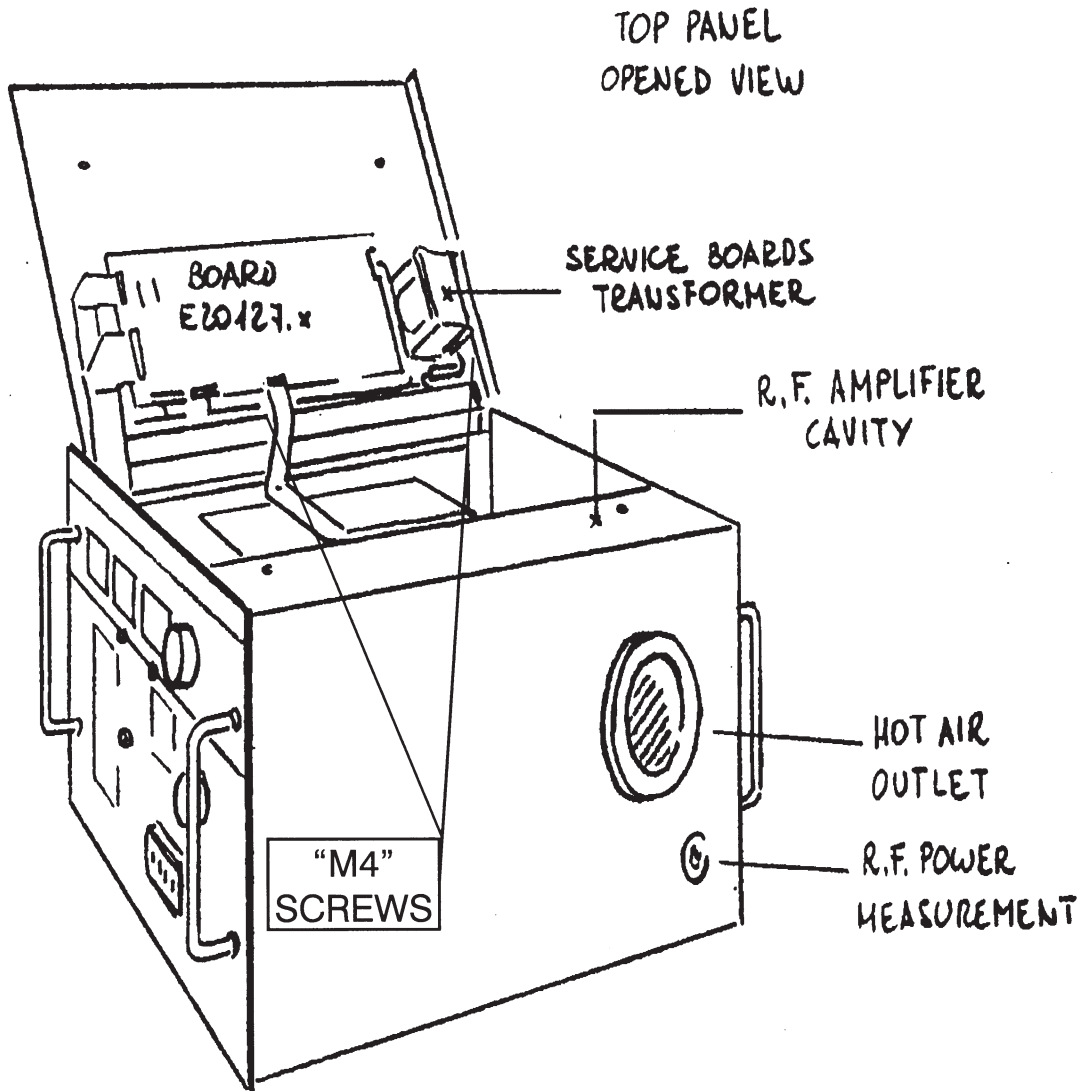

Opened top view

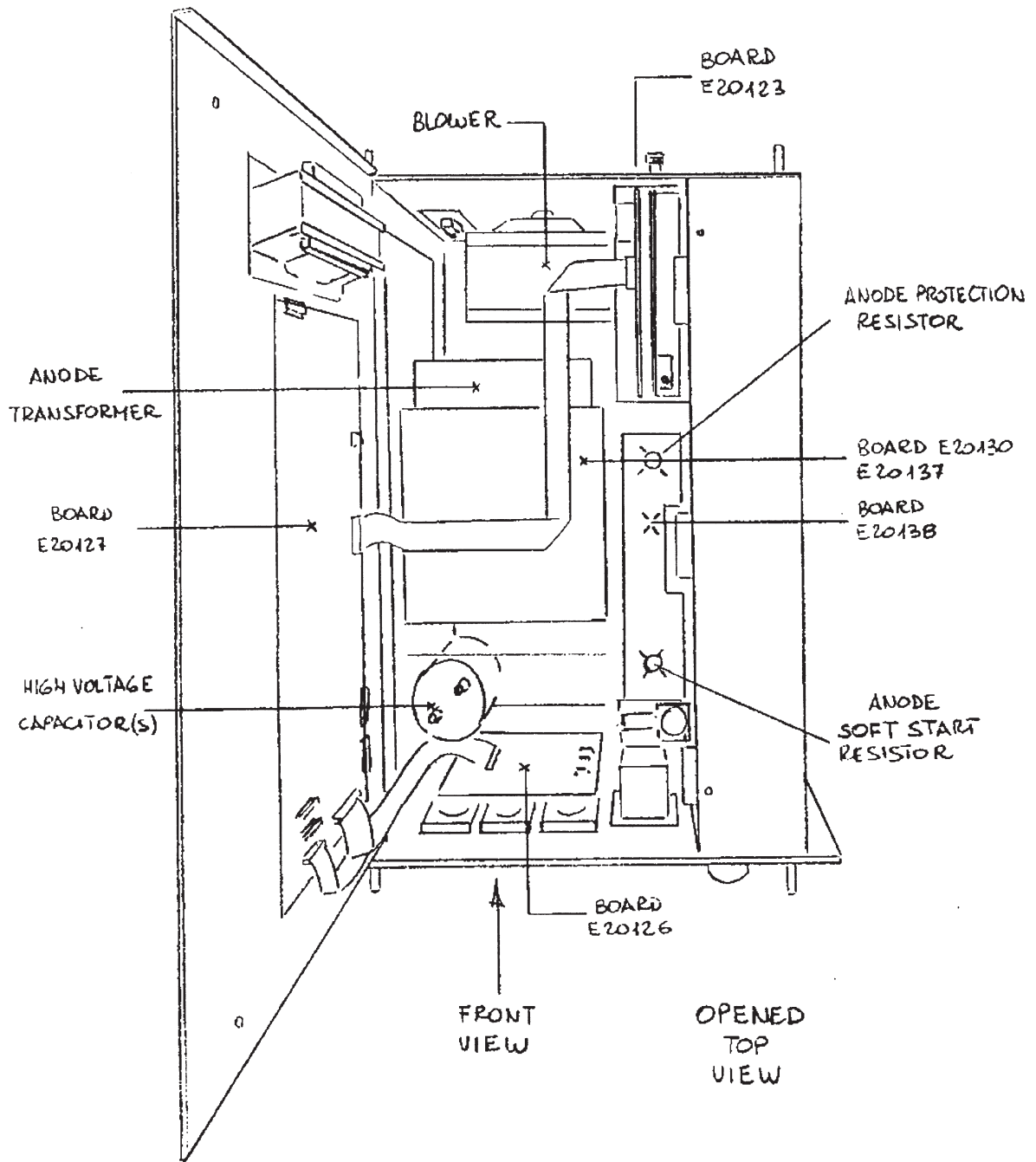

To remove the front panel

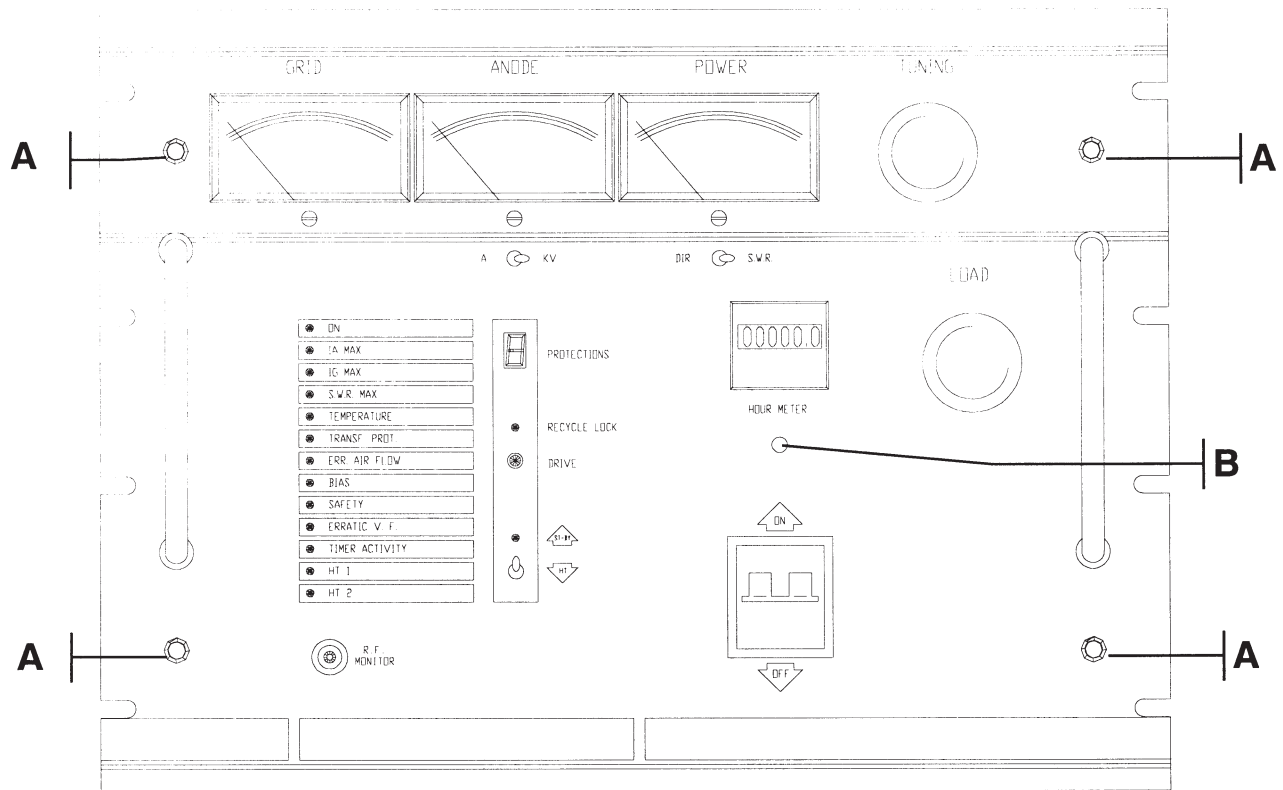

Before removing the front panel make sure to have opened the top cover, as described in the previous section.

- Remove then the flat cables from the CN1 and CN2 connectors in the E20126 card.
- Remove now the TUNING and LOAD knobs.
- Unscrew the 5 mm hex bolts indicated with A
- Unscrew the 3 mm hex bolt indicated with B

To remove the rear panel

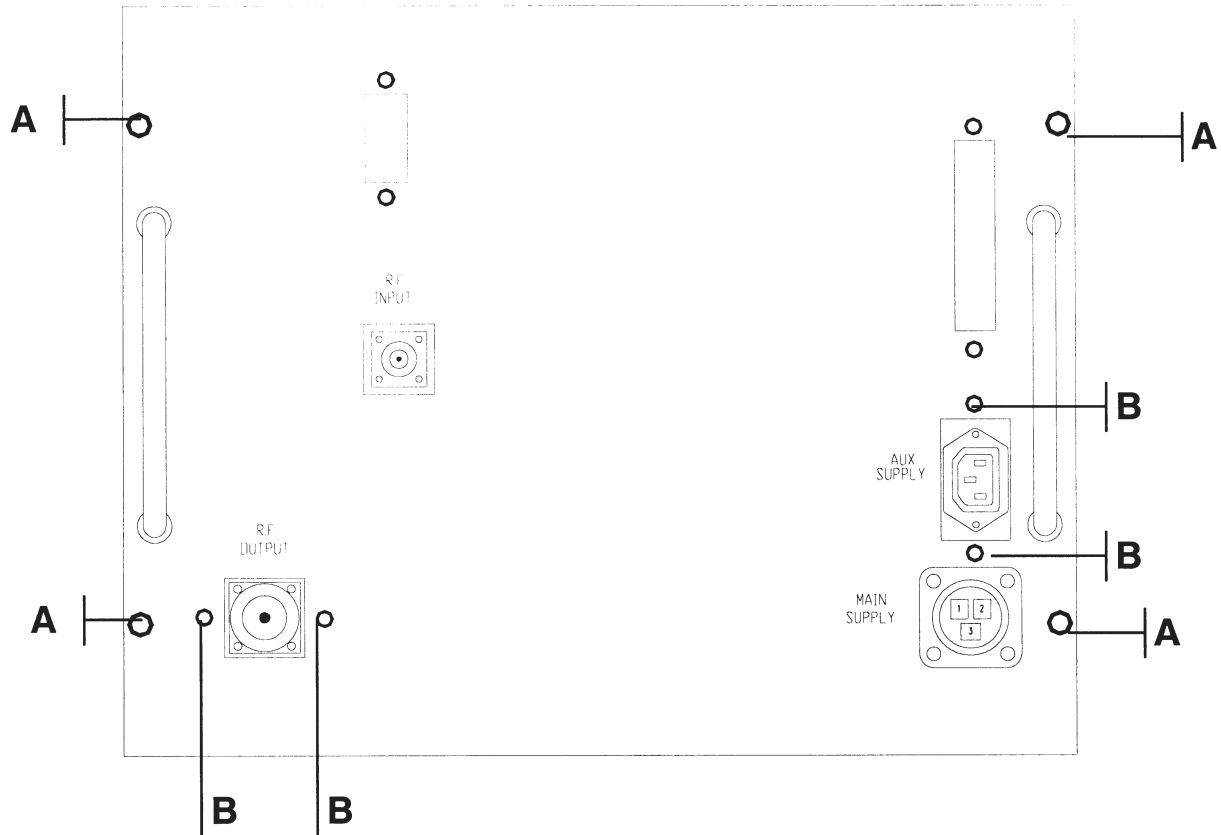

To remove the rear panel follow the following steps:

1. Remove the four 5 mm hex bolts indicated with A ;
2. Remove the four 3 mm hex bolts indicated with B ;
3. In case optional facilities have been installed (APC, RF diagnostic, etc), remove additional hex bolts.

Left side panel removal (and air filter)

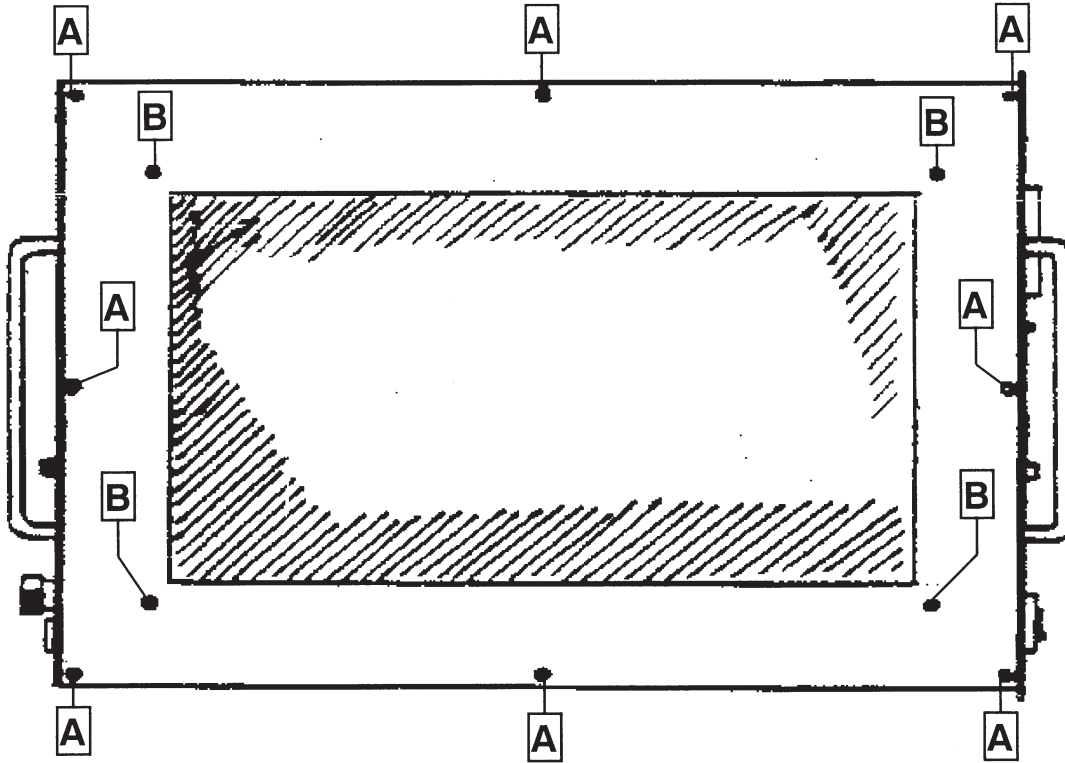

Remove the eight hex screws marked with A, using a 3 mm hex wrench
Remove now the filtering panel and clean the surfaces.
When replacing the filter itself, remove the four hex screws marked with B.

To open RF Amplifier Cavity

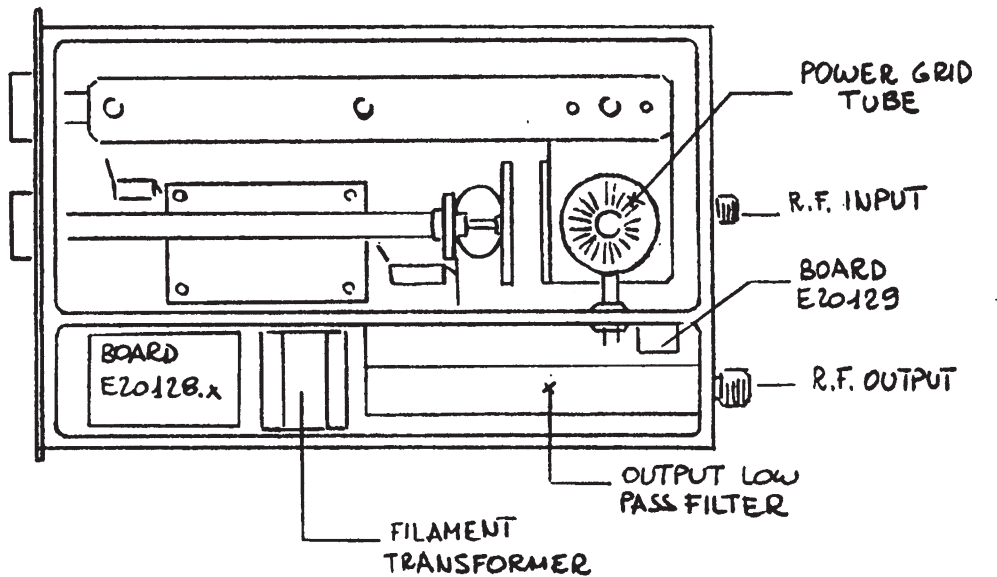
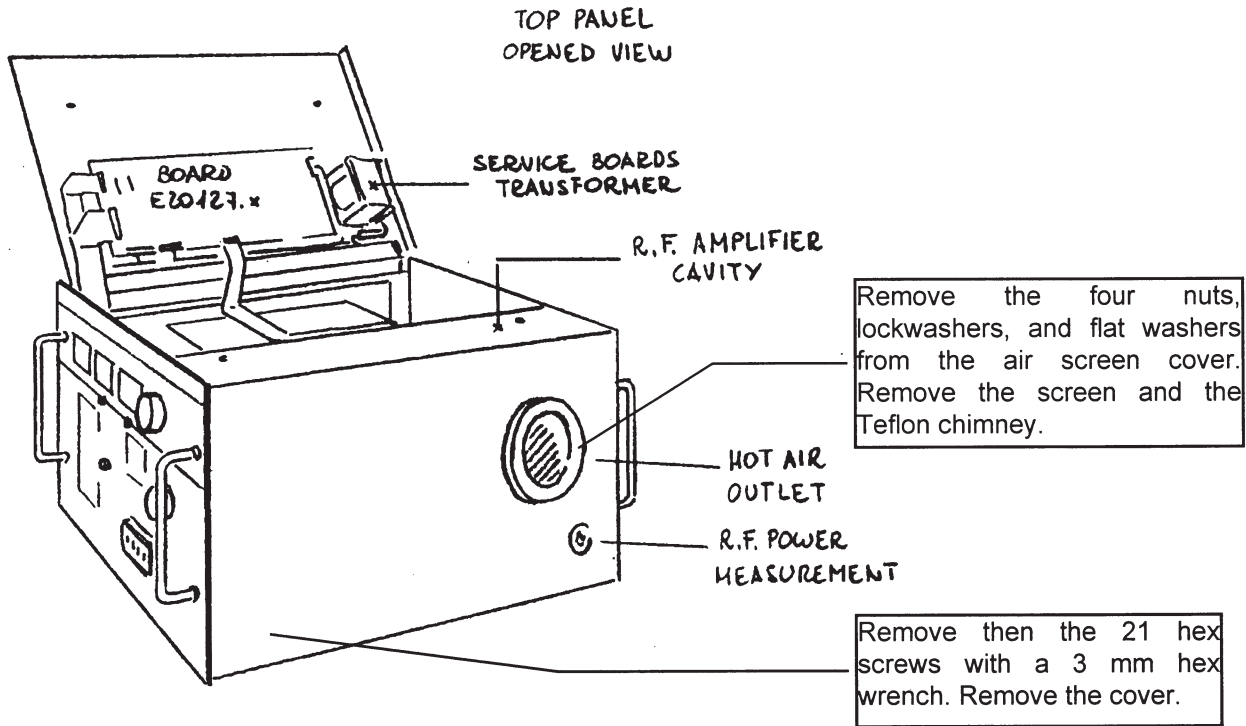

R.F. AMPLIFIER
CAVITY
OPENED VIEW

Removal of the rf compartment

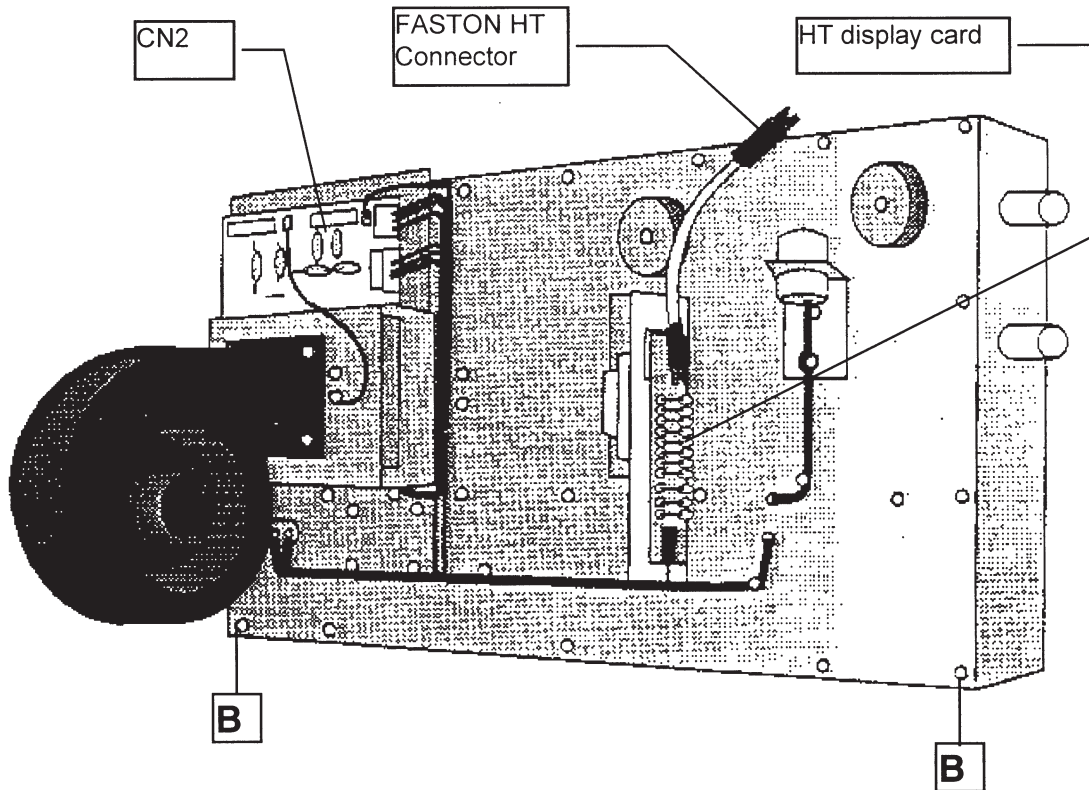

Follow next steps:

1. Open the top cover as described in the related section
2. Remove the front panel as described in the related section
3. Remove the real panel as described in the related section
4. Remove connectors CN3, CN4, CN5 as described in the related section
5. Disconnect the high voltage lead
6. Remove the two blots holding the RF unit to the main chassis

Air flow protection setting

The air flow protection is accessed by removing the blow unit. The switch is located on the blower mounting plate. The microswitch is activated when the air vane move from 10 to 15 mm from its steady state position.

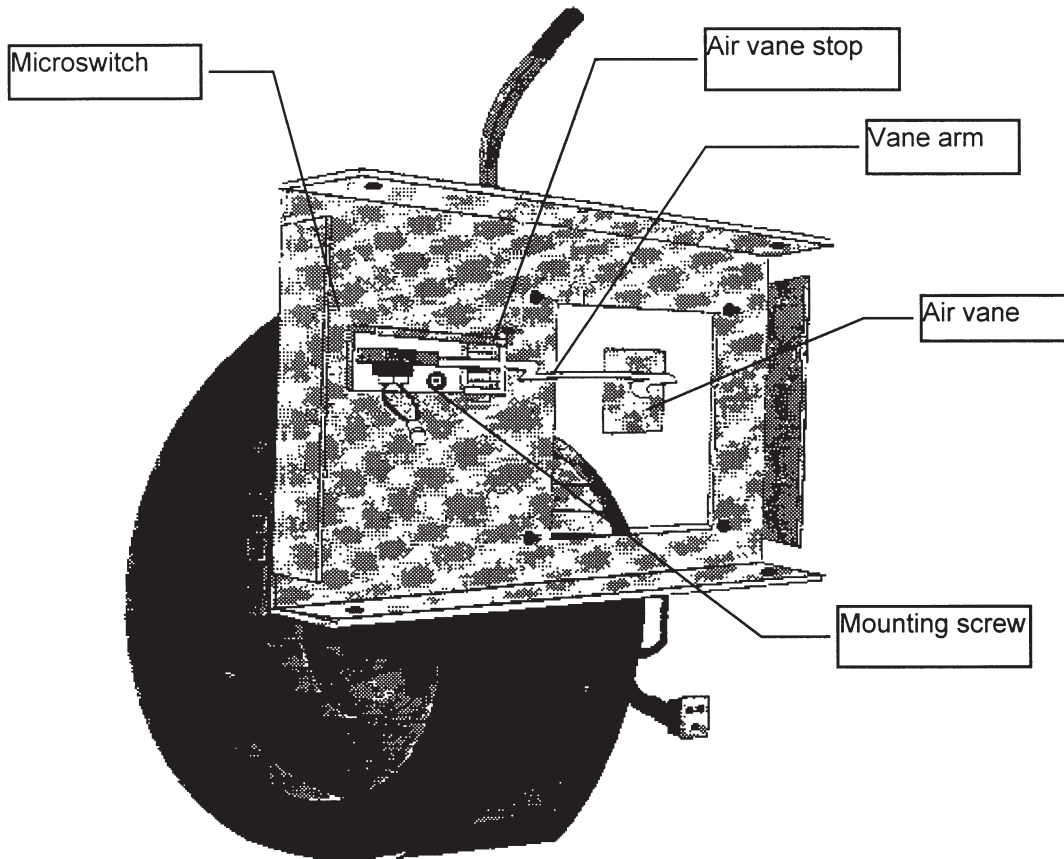

SCHEMATICS :

R.F. Schematic for 3CX1500A7 tube

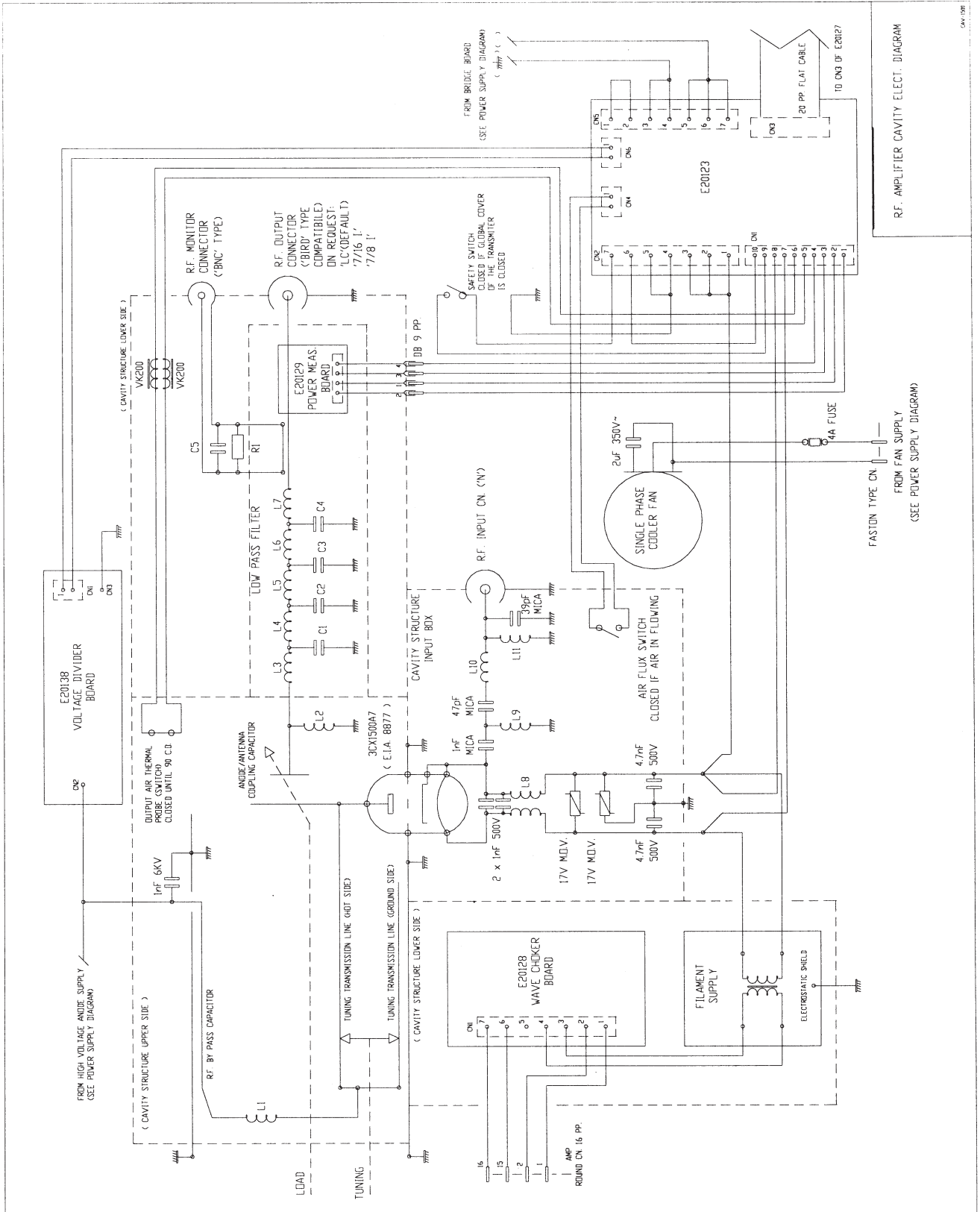

RF. AMPLIFIER CAVITY ELECT. DIAGRAM

FROM FAN SUPPLY (SEE POWER SUPPLY DIAGRAM)

CAV 100

Part List of R.F Amplifier Cavity

Rif.	Description	Value	Remarks	Part code
E20123	Cathode Bias Board			
E20128	Wave Choker Board			
E20129	Power measurement board			
E20138	Voltage divider Board			
Filament supply	Shielded transformer 8.1V 130VA			
Tube	EIMAC 3CX1500A7			
Fan	220V single phase 290 m ³ /h			
Fuse	4A fast 5 x 20			
L1, L2	Coil 1.5 25 turns D=16mm			2L00007
L3	Coil 1.5 AG			2L00020A
L4	Coil 1.5 AG			2L00022A
L5	Coil 1.5 AG			2L00023A
L6	Coil 1.5 AG			2L00022A
L7	Coil 1.5 AG			2L00021A
L8	Bifilar coil 18 turns			2L00006
L9	Coil 1.5 AG 2 turns D=8mm L=6mm			2L00017A
L10	Coil 1.5 AG 4 turns D=8mm L=20mm			2L00016A
L11	Coil 1.5 AG 5 turns D=8mm L=27mm			2L00015A
C1	Teflon capacitor d=2.5 mm			
C2, C3	Teflon capacitor d=2 mm			
C4	Teflon capacitor d=2.5 mm			
C5	Ceramic capacitor p 5mm	22pF		
R1	Resistor 0.25W	49.9 ohm		

R.F. Schematic for 3CX800A7 tube

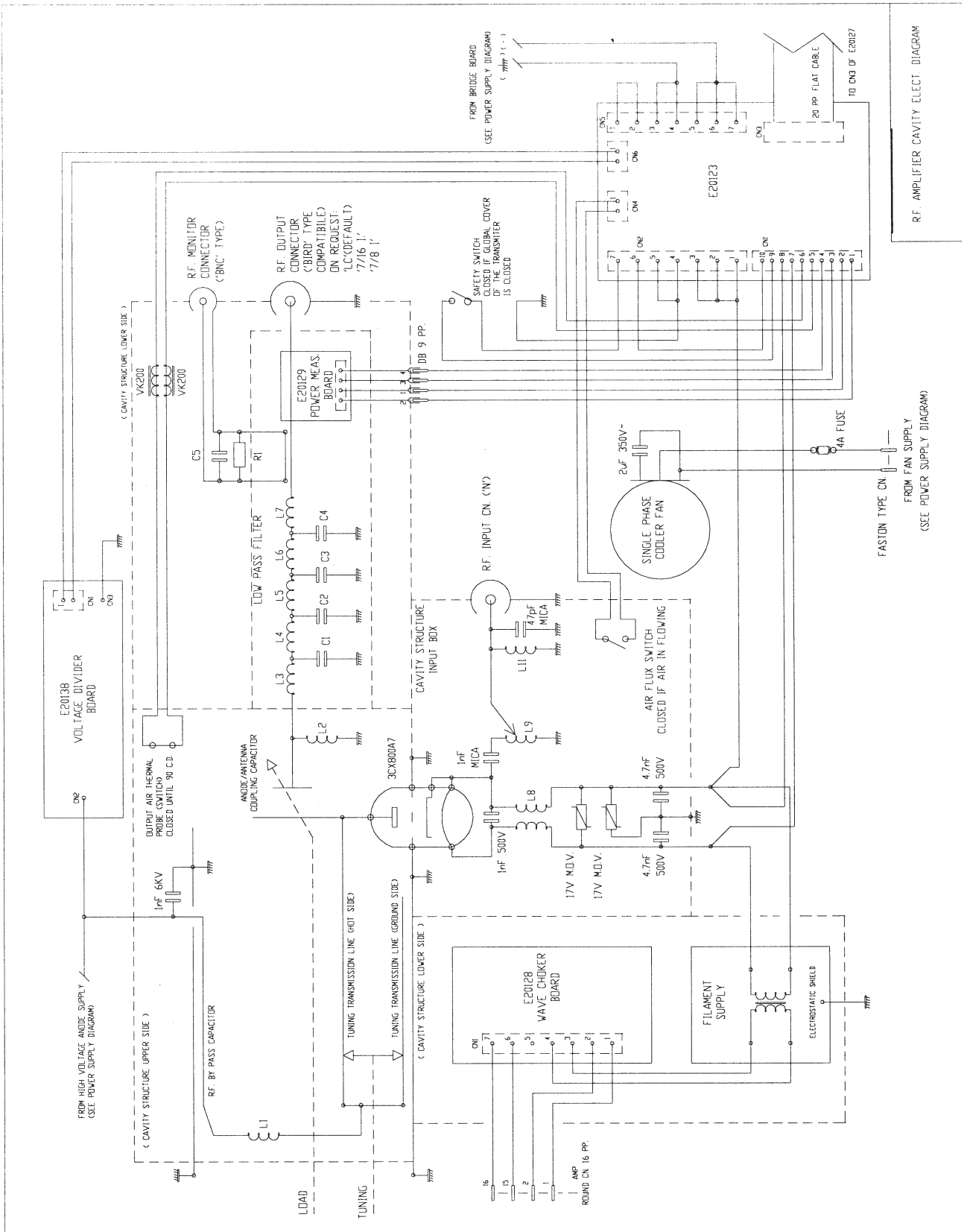

RF AMPLIFIER CAVITY ELECT. DIAGRAM

FROM FAN SUPPLY (SEE POWER SUPPLY DIAGRAM)

FROM BRIDGE BOARD (SEE POWER SUPPLY DIAGRAM)

Part List of R.F Amplifier Cavity T800

Rif.	Description	Value	Remarks	Part code
E20123	Cathode Bias Board			
E20128	Wave Choker Board			
E20129	Power measurement board			
E20138	Voltage divider Board			
Filament supply	Shielded transformer 21V 53VA			
Tube	EIMAC 3CX800A7			
Fan	220V single phase 290 m ³ /h			
Fuse	4A fast 5 x 20			
L1, L2	Coil 1.5 25 turns D=16mm			2L00007
L3	Coil 1.5 AG			2L00020A
L4	Coil 1.5 AG			2L00022A
L5	Coil 1.5 AG			2L00023A
L6	Coil 1.5 AG			2L00022A
L7	Coil 1.5 AG			2L00021A
L8	Bifilar coil 18 turns			2L00006
L9	Coil 1.5 AG 6 turns D=9.5mm			
L11	Coil 1.5 AG 5 turns D=6.5mm			
C1	Teflon capacitor d=2.5 mm			
C2, C3	Teflon capacitor d=2 mm			
C4	Teflon capacitor d=2.5 mm			
C5	Ceramic capacitor p5mm	22pF		
R1	Resistor 0.25W	49.9 ohm		

Part list single phase

Ref.	Description	Value	Remarks	Part code
C1	Capacitor	see sch.	4KV	
C2	Capacitor	see sch.	450V	
Fuse	4A fast			
R1 , R2	Wire wound resistor	60ohm	200W	2RFWW060
HT1, HT2	Relay 30A 24VAC / 250VAC			
HT2 AUX	Relay 10A 24VAC/250VAC 2-way			
Grid Meter Anode Meter Power Meter	Meter 100uA f.s. M3D			
MOV1, MOV2	MOV type S20K-275			
Anode Transf. T800 T1200 T1500 T1800	3000VA 2500V 3000VA 2500V 4100VA 2950V 5500VA 2975V			
Service Transformer	80VA			
A/KV Switch DIR/SWR Switch	Switch 2-way 2-pos.	250V	6.3A	
Main Switch T1800 others	Switch 2p 32A Switch 2p 25A			

Part List three-phase

Rif.	Description	Value	Remarks	Part code
C1	Capacitor	8 uF	4KV	2CFO0001
Fuse	4A fast			
R1	Wire wound resistor	60ohm	200W	2RFWW060
RR1	3 x Wire wound resistor	3 x 20ohm	100W	2RFWWA23
HT1, HT2	Power contactors	11KVA		1TLC0003
Transf. protection		13-18A		
Grid Meter Anode Meter Power Meter	Meter 100uA f.s. M3D			
MOV1 - MOV4	Mov type S20K-275			
Anode Transf. T2000 T800 T1200	5KVA 2825V 2500VA 2800V			
Service Transf.	80VA			
A/KV Switch DIR/SWR Switch	Switch 2-way 2-pos.	250V	6.3A	
Main Switch	3P + N, 25A			

E20123 - Bias Board

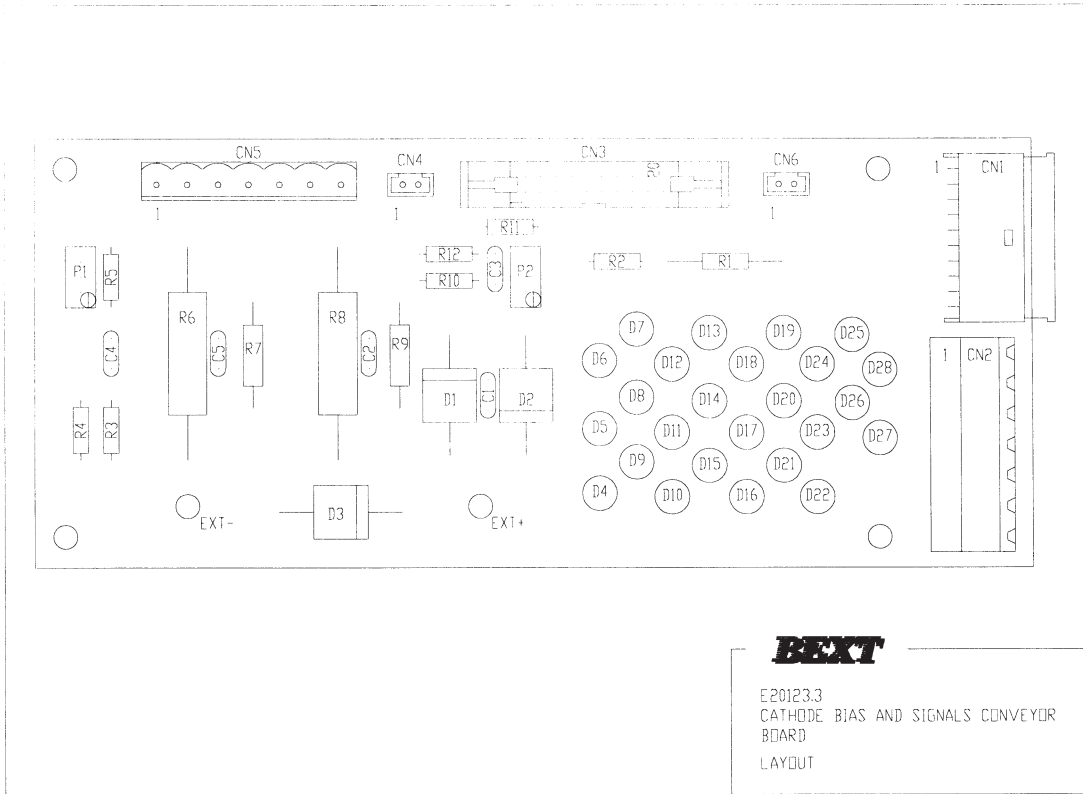

Part List of 20123.3 Board

Rif.	Description	Value	Remarks
PCB	Board code 2PCB0167		
R1	Resistor	196K	0.25 W 1%
R2	Resistor	34K	0.25 W 1%
R3, R4, R5	Resistor	49.9	0.25 W 1%
R6	Resistor wire wound	0.12	5 W 1%
R7	Resistor	100	0.5 W 1%
R8	Resistor wire wound	1	5 W 1%
R9	Resistor	100	0.5 W 1%
R10	Resistor	49.9	0.25 W 1%
R11	Resistor	100	0.25 W 1%
R12	Resistor	49.9	0.25 W 1%
P1, P2	Trimmer type 67W	100	
C1, C2, C3, C4, C5	Ceramic Capacitor	100 nF	50 V
D1, D2, D3	Diode silicon type P600K		6A 800V
D4 - D28	Diode silicon type BY255		
CN1	AMP connector MODU male 10 pin Angled		
CN2	Phoenix Connector male 7 pin Angled		
CN3	ANSLEY connector 10+10 pin Straight		
CN4	AMP connector MODU male 2 pin Straight		
CN5	Phoenix Connector male 7 pin Straight		
CN6	AMP connector MODU male 2 pin Straight		
EXT+, EXT-	Fixing Stud F/M		

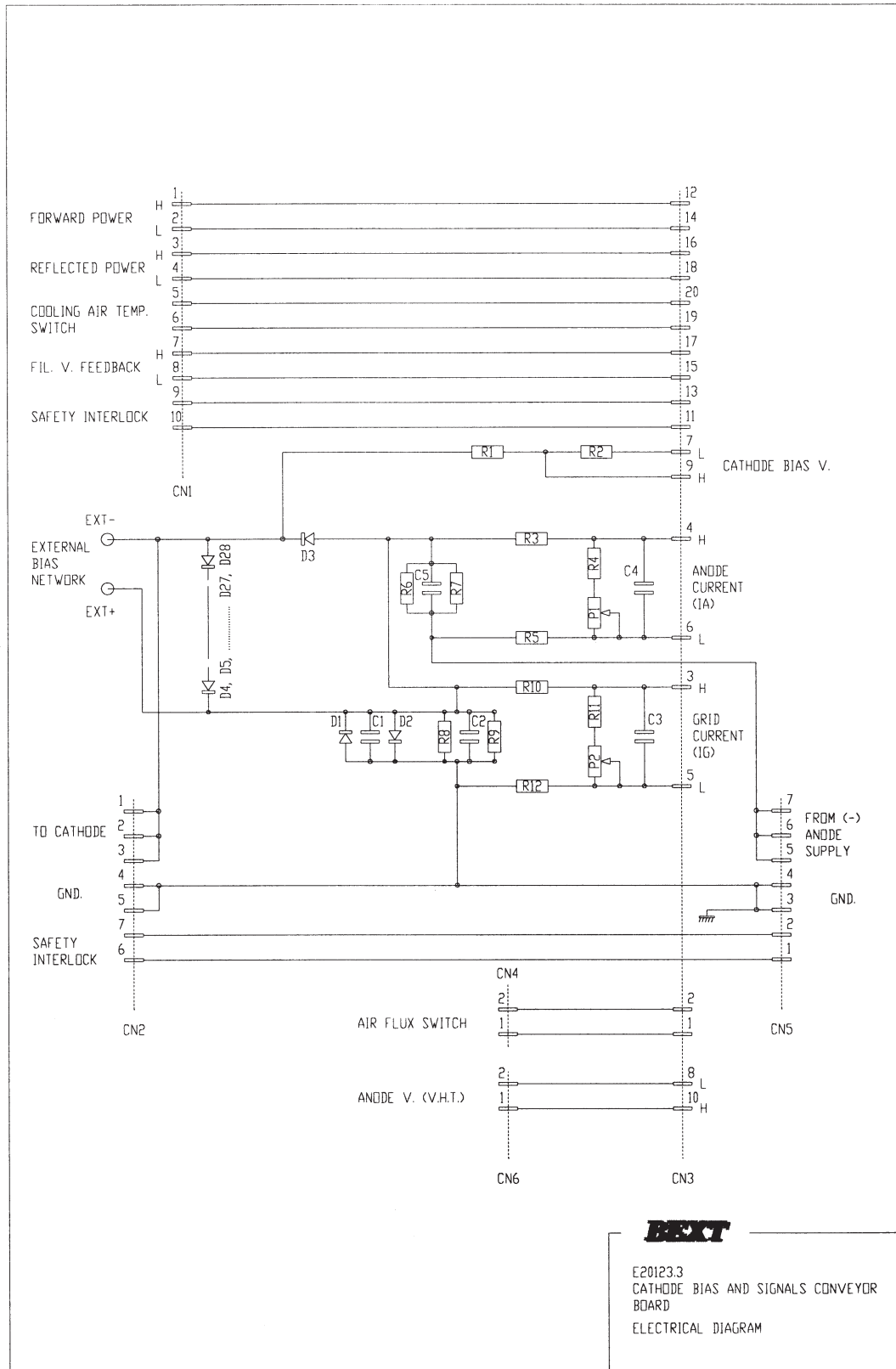

BENT

E20123.3
 CATHODE BIAS AND SIGNALS CONVEYOR
 BOARD
 ELECTRICAL DIAGRAM

E20126 - Front panel board

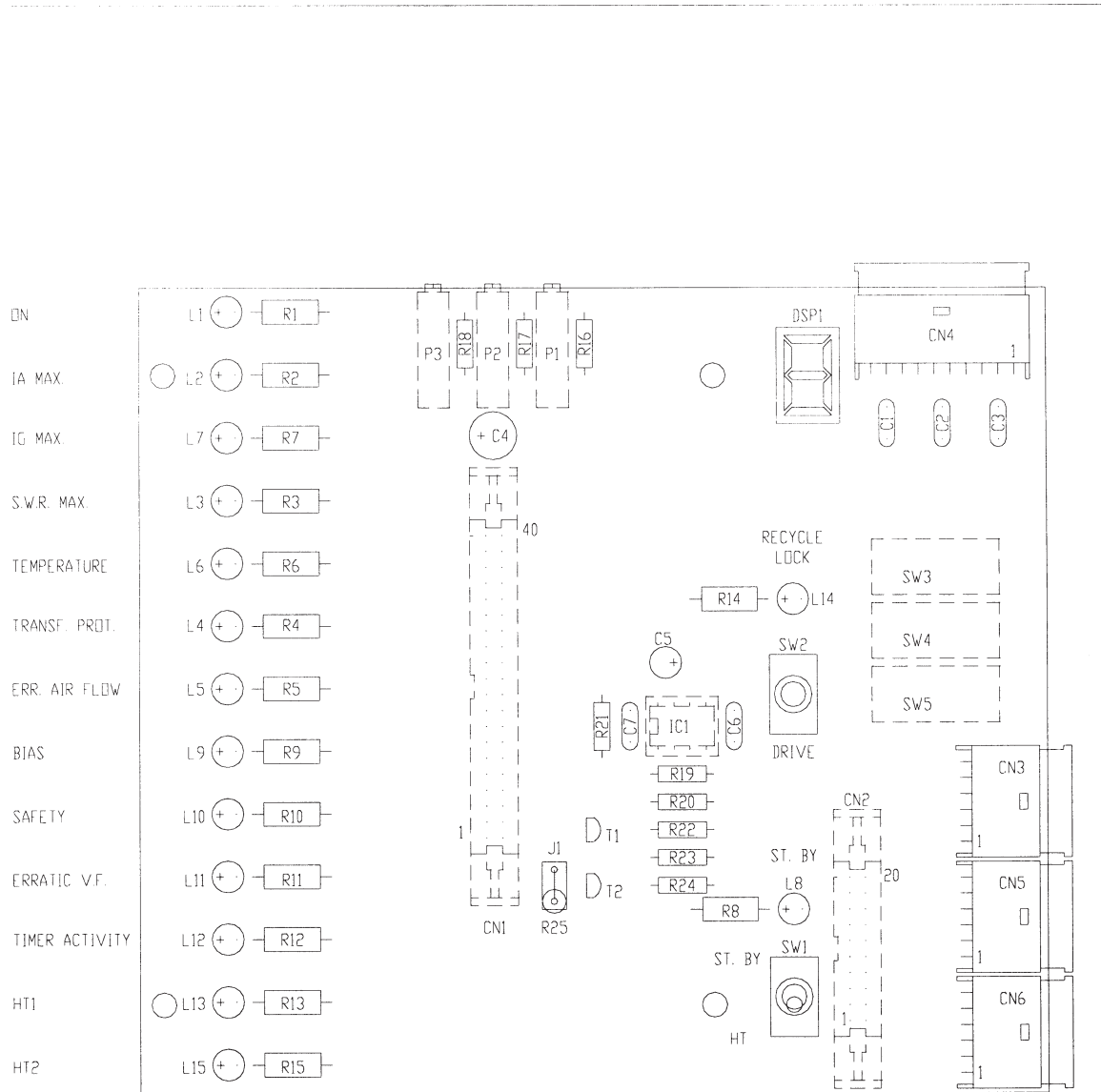

Note: CN1, CN2, P1, P2, P3,
 IC1, SW3, SW4, SW5
 ARE MOUNTED ON THE REAR



E20126.3
 FRONT PANEL BOARD LAYOUT

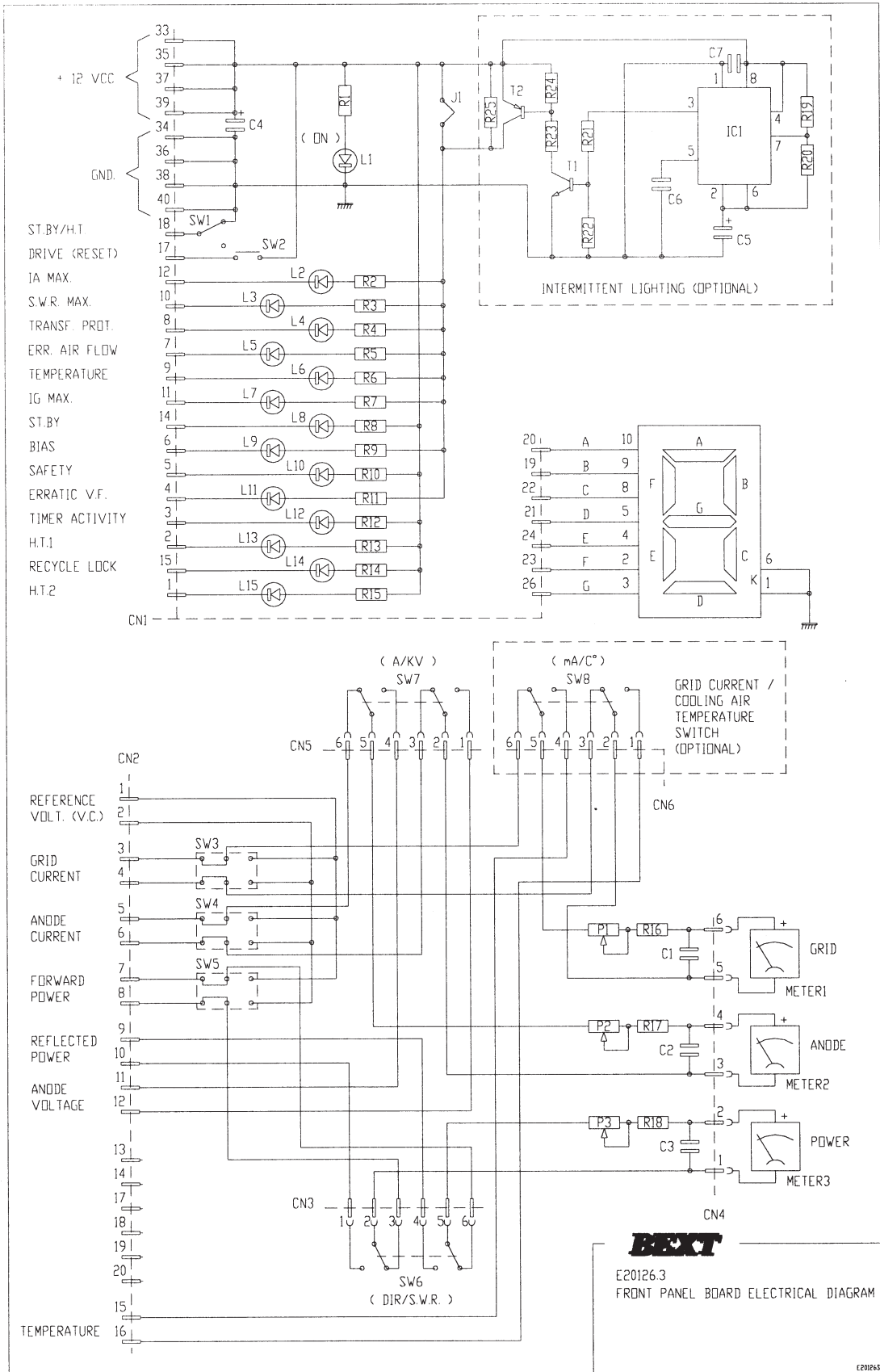

Part List of E20126.3 Board

Rif.	Description	Value	Remarks
PCB1	Board Code 2PCB0161		
R1 - R15	Resistor	820R	0.25W 1%
R16 - R18	Resistor	15K	0.25W 1%
P1 -P3	Trimmer type 89P	10K	
C4	Electrolytic Capacitor	10 uF	63V
L1	Led Green 5 mm.		
L2 - L12	Led Red 5 mm.		
L13	Led Green 5 mm.		
L14	Led Red 5 mm.		
L15	Led Green 5 mm.		
DSP1	Display type FND367		
J1	Copper wire		
CN1	ANSLEY Connector 20+20 pin straight		
CN2	ANSLEY Connector 10+10 pin straight		
CN3	AMP connector 6 pin angled		
CN4	AMP connector 10 pin angled		
CN5	AMP connector 6 pin angled		
SW1	Single switch 2 position		
SW2	Push button		
SW3 - SW5	Double Sliding Contact Commutator		

E20127 - Control board

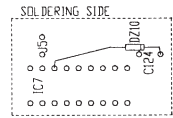
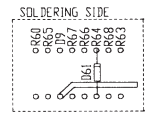
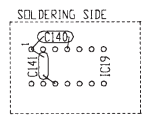
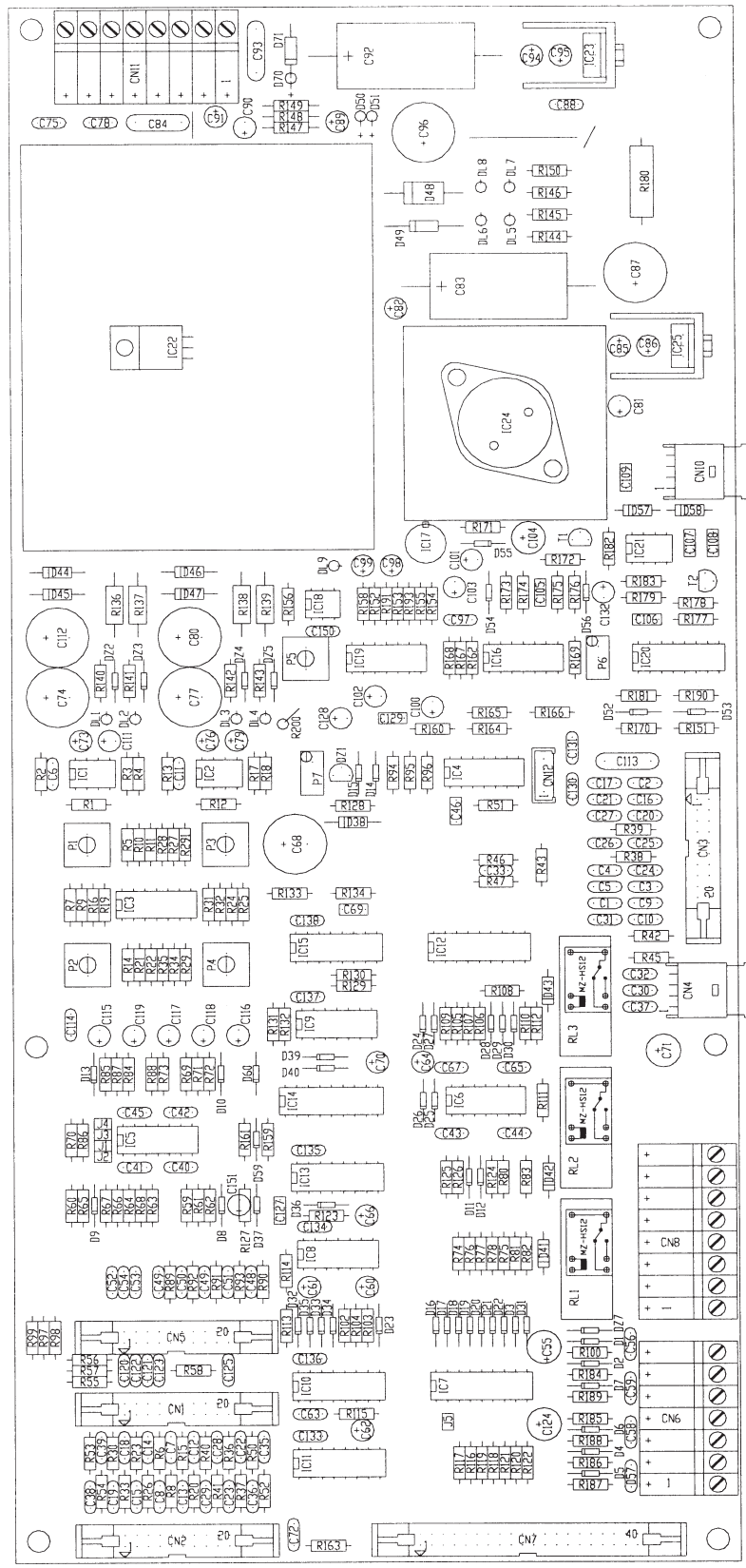

E20127 GENERAL CONTROL BOARD LAYOUT

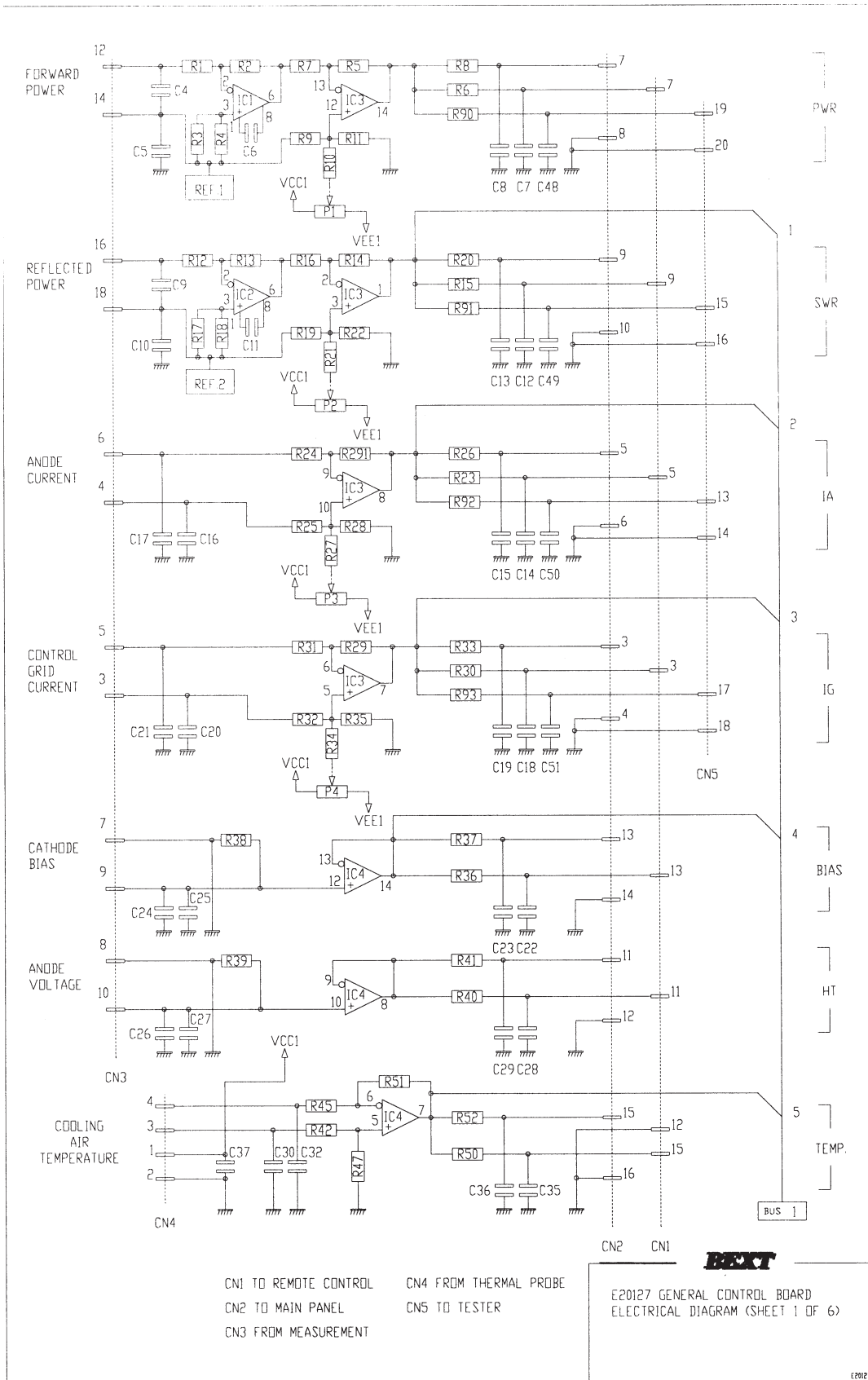

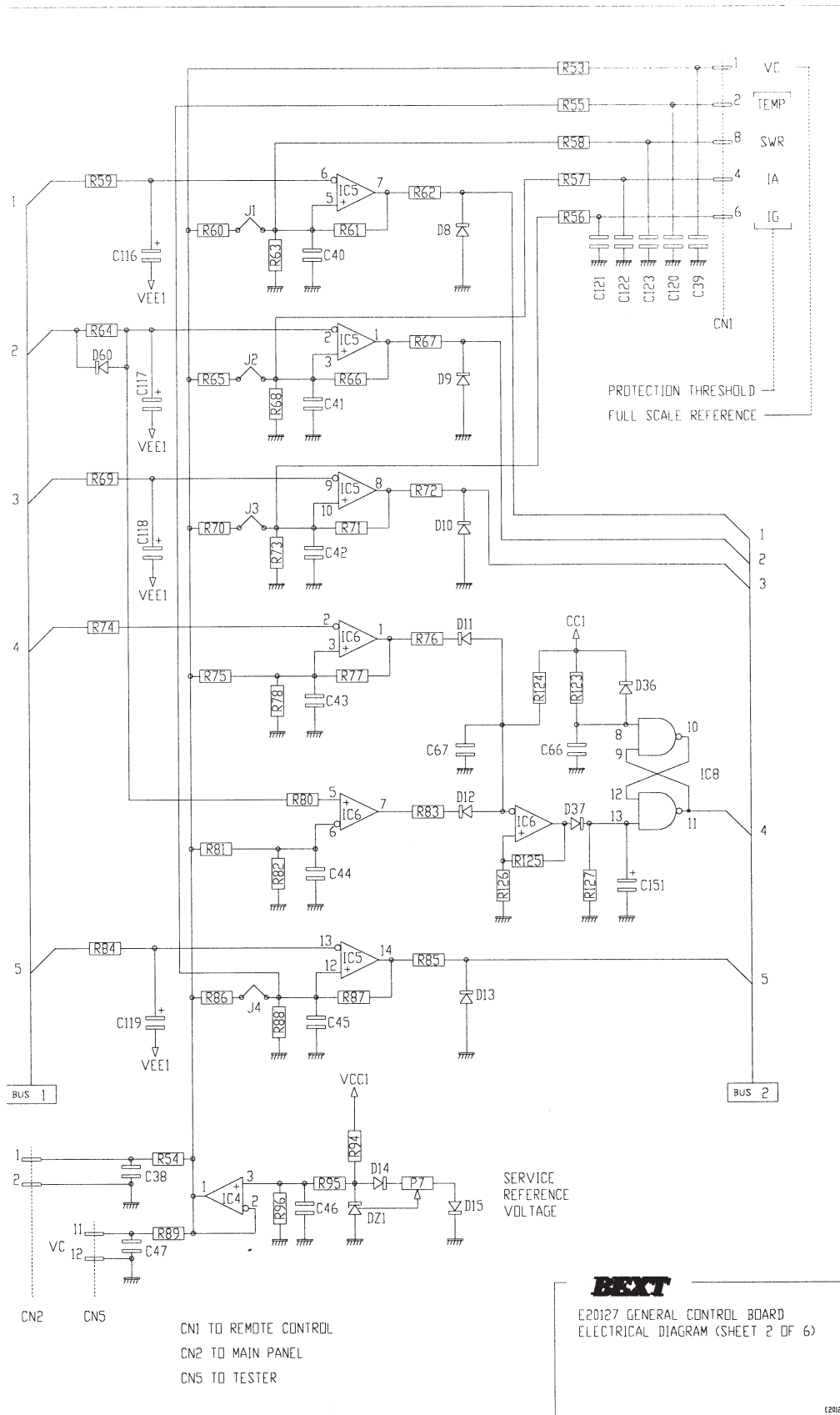

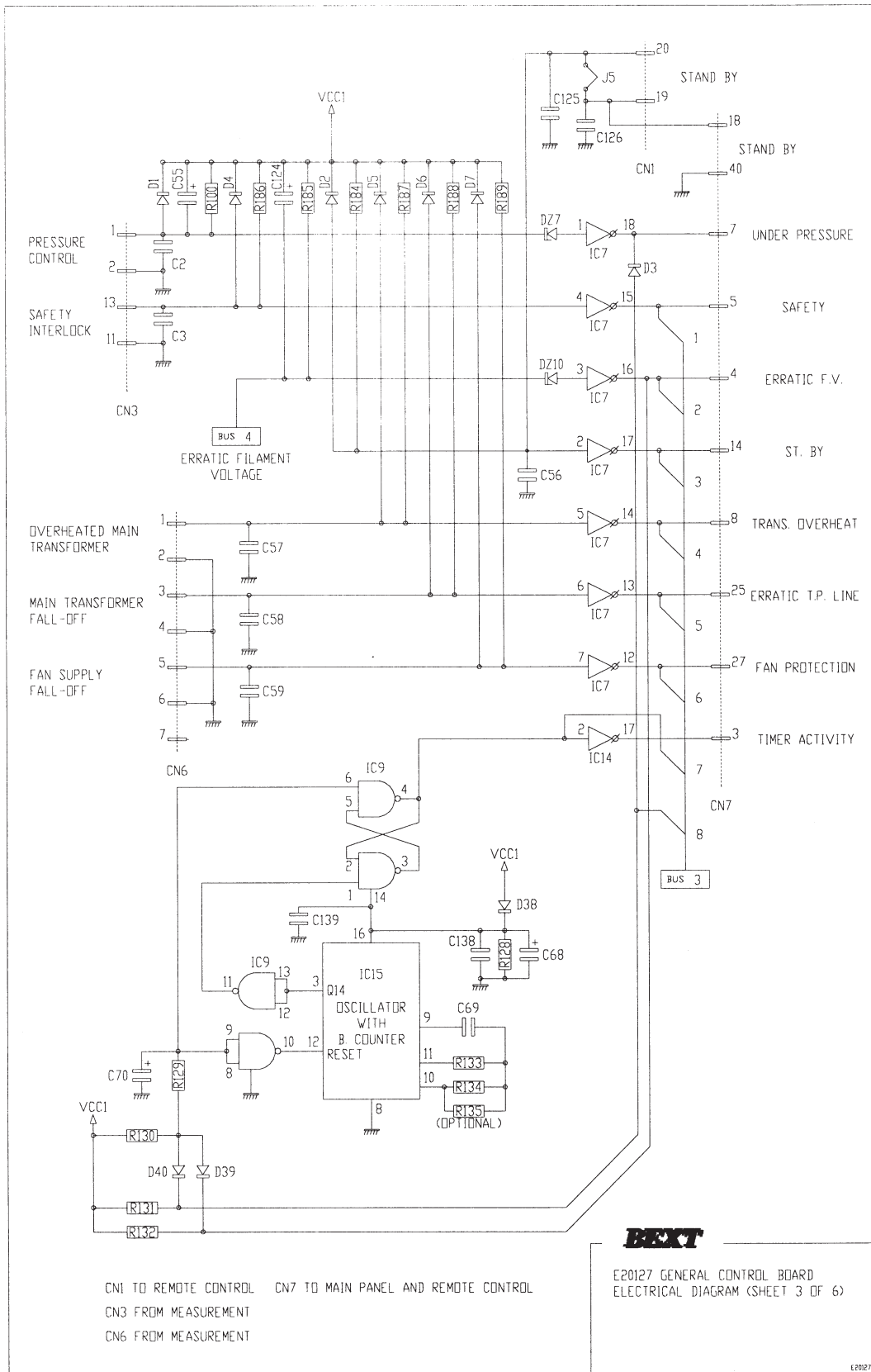

CN1 TO REMOTE CONTROL CN7 TO MAIN PANEL AND REMOTE CONTROL
 CN3 FROM MEASUREMENT
 CN6 FROM MEASUREMENT



E20127 GENERAL CONTROL BOARD
 ELECTRICAL DIAGRAM (SHEET 3 OF 6)

Compact Series Handbook - 44

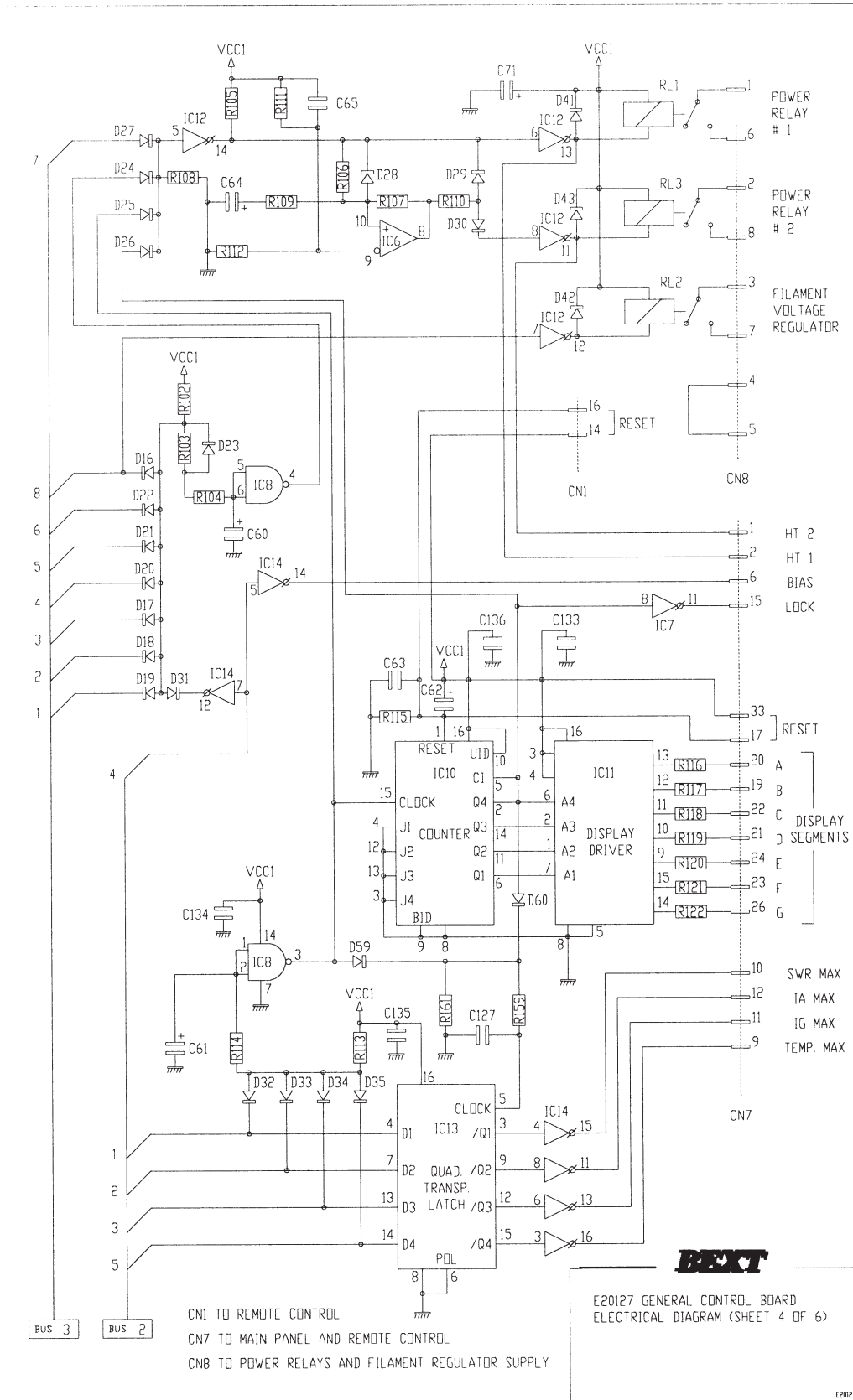

BEET
 E20127 GENERAL CONTROL BOARD
 ELECTRICAL DIAGRAM (SHEET 4 OF 6)
 E20127D

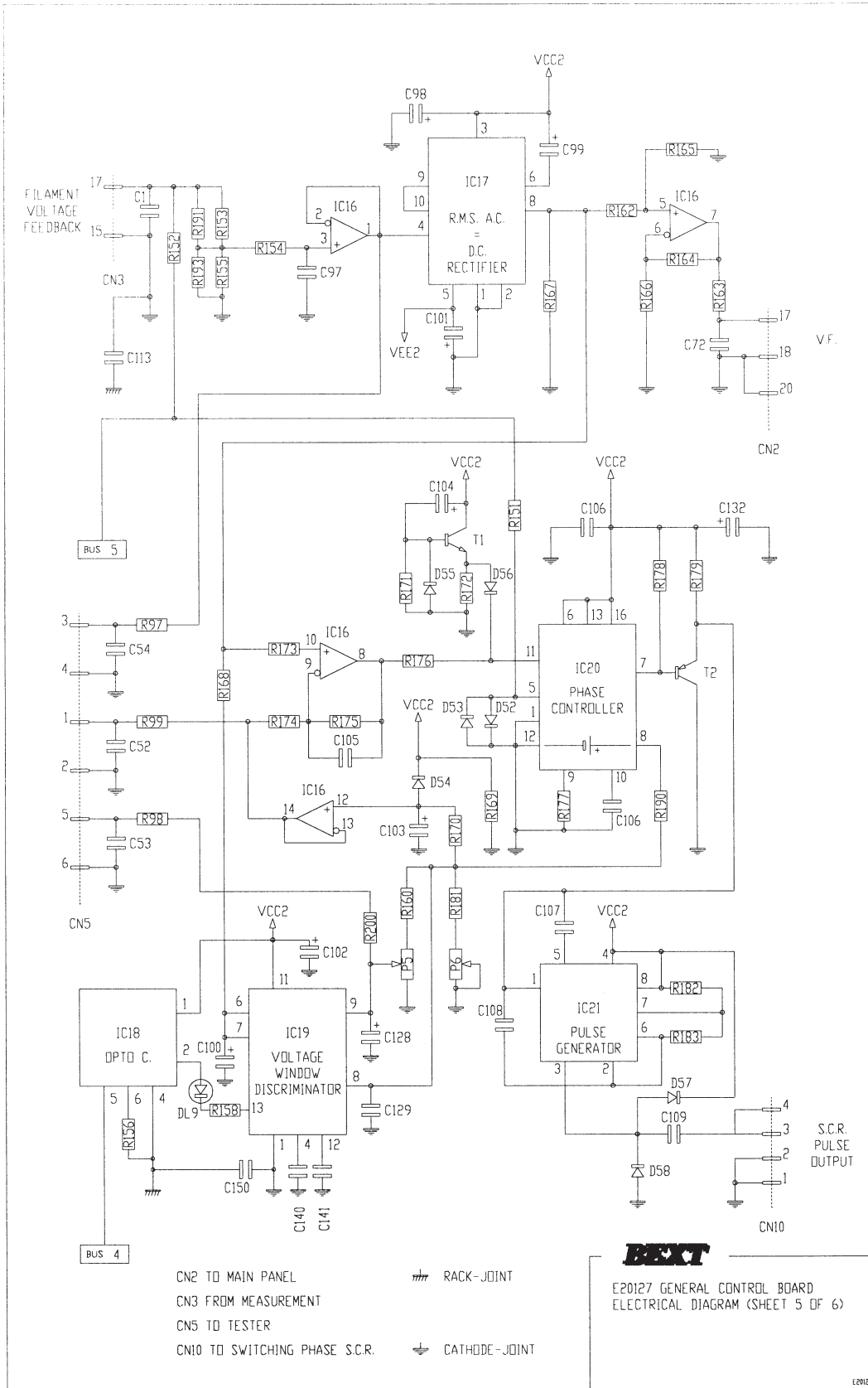

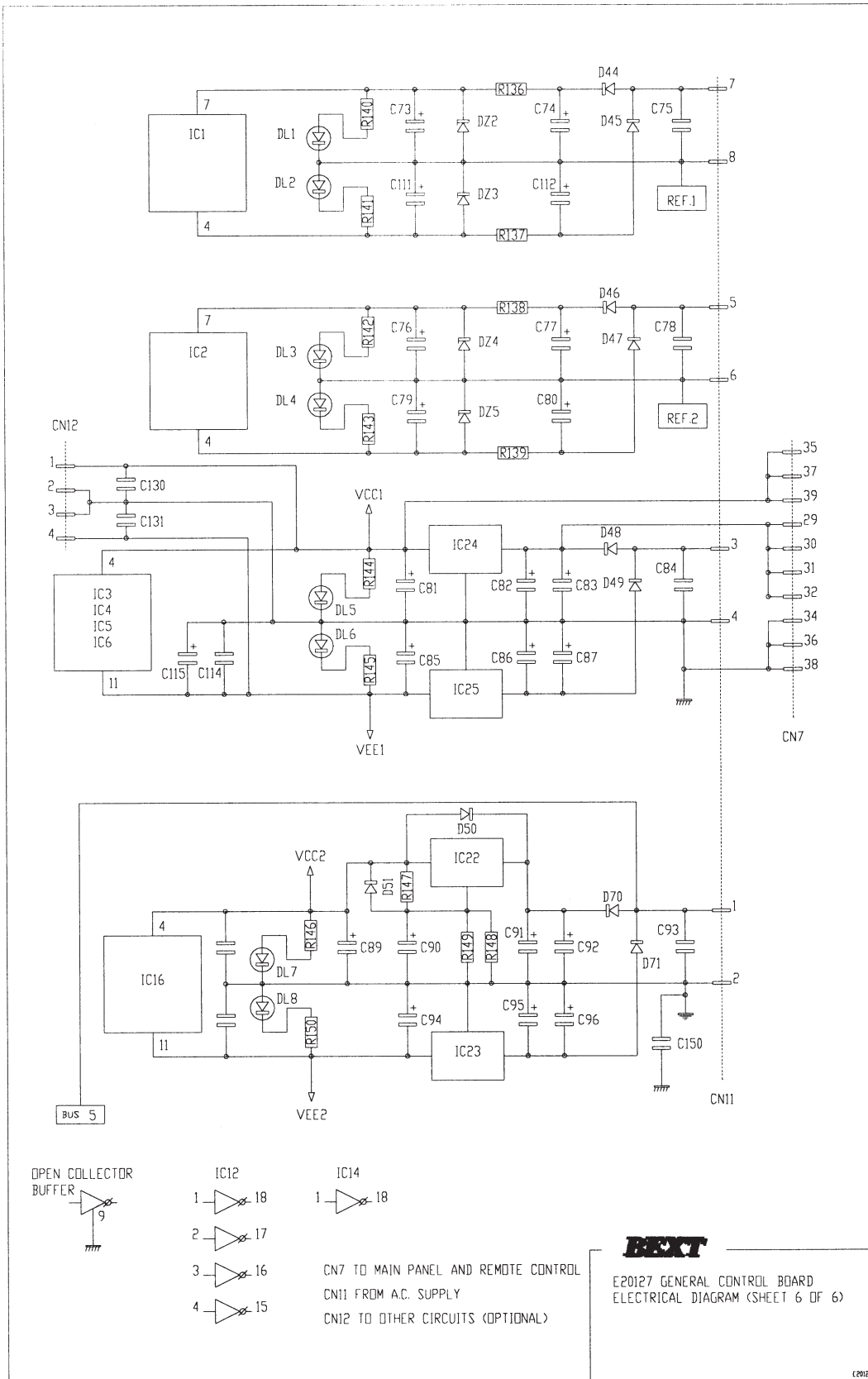

Part List of 20127 Board

* variable value

Rif.	Description	Value	Remarks
R1	Resistor	1300	0.25 W 1%
R2	Resistor	2000	0.25 W 1%
R3	Resistor	1300	0.25 W 1%
R4	Resistor	2000	0.25 W 1%
R5	Resistor	34 K	0.25 W 1%
R6	Resistor	100	0.25 W 1%
R7	Resistor	1020	0.25 W 1%
R8	Resistor	100	0.25 W 1%
R9	Resistor	1020	0.25 W 1%
R10	Resistor	1 M	0.25 W 1%
R11	Resistor	34 K	0.25 W 1%
R12	Resistor	1300	0.25 W 1%
R13	Resistor	2000	0.25 W 1%
R14	Resistor	34 K	0.25 W 1%
R15	Resistor	100	0.25 W 1%
R16	Resistor	1020	0.25 W 1%
R17	Resistor	1300	0.25 W 1%
R18	Resistor	2000	0.25 W 1%
R19	Resistor	1020	0.25 W 1%
R20	Resistor	100	0.25 W 1%
R21	Resistor	1 M	0.25 W 1%
R22	Resistor	34 K	0.25 W 1%
R23	Resistor	100	0.25 W 1%
R24, R25	Resistor	1020	0.25 W 1%
R26	Resistor	100	0.25 W 1%
R27	Resistor	1 M	0.25 W 1%
R28, R29	Resistor	34 K	0.25 W 1%
R30	Resistor	100	0.25 W 1%
R31, R32	Resistor	1020	0.25 W 1%
R33	Resistor	100	0.25 W 1%
R34	Resistor	1 M	0.25 W 1%
R35	Resistor	34 K	0.25 W 1%
R36, R37	Resistor	100	0.25 W 1%
R38, R39	Resistor	34 K	0.25 W 1%
R40, R41	Resistor	100	0.25 W 1%
R42	Resistor	*	0.25 W 1%
R43	Resistor	*	0.25 W 1%
R45	Resistor	*	0.25 W 1%
R46	Resistor	*	0.25 W 1%
R47	Resistor	*	0.25 W 1%
R50	Resistor	100	0.25 W 1%
R51	Resistor	34 K	0.25 W 1%
R52, R53	Resistor	100	0.25 W 1%
R54	Resistor	*	0.25 W 1%
R55, R56, R57, R58	Resistor	100	0.25 W 1%

R59	Resistor	10K	0.25 W 1%
R60	Resistor	*	0.25 W 1%
R61	Resistor	10 M	0.25 W 1%
R62, R63	Resistor	10K	0.25 W 1%
R65	Resistor	*	0.25 W 1%
R66	Resistor	10 M	0.25 W 1%
R67	Resistor	10K	0.25 W 1%
R68	Resistor	1 K	0.25 W 1%
R69	Resistor	100 K	0.25 W 1%
R70	Resistor	*	0.25 W 1%
R71	Resistor	10 M	0.25 W 1%
R72, R73, R74	Resistor	10K	0.25 W 1%
R75	Resistor	*	0.25 W 1%
R76	Resistor	10 K	0.25 W 1%
R77	Resistor	10 M	0.25 W 1%
R78	Resistor	10 K	0.25 W 1%
R80	Resistor	1 K	0.25 W 1%
R81	Resistor	*	0.25 W 1%
R82, R83,R84,R85	Resistor	10 K	0.25 W 1%
R86	Resistor	1.8 K	0.25 W 5%
R87	Resistor	10 M	0.25 W 1%
R88	Resistor	10 K	0.25 W 1%
R89, R90	Resistor	100	0.25 W 1%
R91, R92, R93	Resistor	100	0.25 W 1%
R94	Resistor	6810	0.25 W 1%
R95	Resistor	34 K	0.25 W 1%
R96	Resistor	137 K	0.25 W 1%
R97, R98, R99	Resistor	100	0.25 W 1%
R100	Resistor	10 K	0.25 W 1%
R102	Resistor	1K	0.25 W 1%
R103	Resistor	100 K	0.25 W 1%
R104, R105	Resistor	10 K	0.25 W 1%
R106	Resistor	100 K	0.25 W 1%
R107	Resistor	10 M	0.25 W 1%
R108	Resistor	10 K	0.25 W 1%
R109	Resistor	100	0.25 W 1%
R110, R111, R112	Resistor	10 K	0.25 W 1%
R113	Resistor	100 K	0.25 W 1%
R114	Resistor	100	0.25 W 1%
R115	Resistor	10 K	0.25 W 1%
R116,R117,R118, R119,R120,R121, R122	Resistor	1K	0.25 W 1%
R123, R124	Resistor	100 K	0.25 W 1%
R125	Resistor	10 M	0.25 W 1%
R126	Resistor	10 K	0.25 W 1%
R127	Resistor	4750	0.25 W 1%
R128	Resistor	1 K	0.25 W 1%
R129	Resistor	100 K	0.25 W 1%
R130, R131, R132	Resistor	10 K	0.25 W 1%
R133	Resistor	475 K	0.25 W 1%

R134	Resistor	150 K	0.25 W 1%
R136 - R139	Resistor	150	0.5 W 5%
R140 - R143	Resistor	100	0.25 W 1%
R144 -R147	Resistor	1 K	0.25 W 1%
R148	Resistor	15 K	0.25 W 1%
R149	Resistor	22 K	0.25 W 1%
R150	Resistor	1 K	0.25 W 1%
R151	Resistor	15 K	0.25 W 1%
R152	Resistor	*	0.25 W 1%
R153	Resistor	*	0.25 W 1%
R154	Resistor	10 K	0.25 W 1%
R155	Resistor	1 K	0.25 W 1%
R156	Resistor	150 K	0.25 W 1%
R158	Resistor	1 K	0.25 W 1%
R159, R160, R161	Resistor	100 K	0.25 W 1%
R162	Resistor	10 K	0.25 W 1%
R163	Resistor	100	0.25 W 1%
R164, R165	Resistor	15 K	0.25 W 1%
R166 - R169	Resistor	10 K	0.25 W 1%
R170, R171, R172	Resistor	475 K	0.25 W 1%
R173	Resistor	6810	0.25 W 1%
R174	Resistor	1 K	0.25 W 1%
R175	Resistor	475 K	0.25 W 1%
R176	Resistor	2.2 K	0.25 W 5%
R177	Resistor	82 K	0.25 W 5%
R178, R179	Resistor	10 K	0.25 W 1%
R180	Resistor	270	2 W 5%
R181	Resistor	10 K	0.25 W 1%
R182, R183	Resistor	6810	0.25 W 1%
R184 - R189	Resistor	10 K	0.25 W 1%
R190	Resistor	6810	0.25 W 1%
R191	Resistor	*	0.25 W 1%
R193	Resistor	*	0.25 W 1%
R200	Resistor	1 K	0.25 W 1%
R291	Resistor	34 K	0.25 W 1%
P1 - P4	Trimmer type 72P	100K	
P5	Trimmer type 72P	10K	
P6, P7	Trimmer type 67W	10K	
C1 - C5	Ceramic Capacitor	4.7 nF	50V
C6	Ceramic Capacitor	33 pF	50V
C7 - C10	Ceramic Capacitor	4.7 nF	50V
C11	Ceramic Capacitor	33 pF	50V
C12 -C25	Ceramic Capacitor	4.7 nF	50V
C26	Mylar Capacitor	220 nF	63V
C27	Mylar Capacitor	100 nF	63V
C28, C29	Ceramic Capacitor	4.7 nF	50V
C30	Ceramic Capacitor	*	50V
C31	Ceramic Capacitor	*	50V
C32	Ceramic Capacitor	*	50V
C33	Ceramic Capacitor	*	50V
C35, C36	Ceramic Capacitor	4.7 nF	50V

C37	Ceramic Capacitor	*	50V
C38, C39	Ceramic Capacitor	4.7 nF	50V
C40 - C46	Ceramic Capacitor	100 nF	63V
C47 - C54	Ceramic Capacitor	4.7 nF	50V
C55	Electrolytic Vert. Capacitor	100 uF	35V
C56 - C59	Ceramic Capacitor	4.7 nF	50V
C60 - C62	Electrolytic. Vert. Capacitor	10 uF	35V
C63	Ceramic Capacitor	4.7 nF	50V
C64	Electrolytic. Vert. Capacitor	10 uF	35V
C65	Ceramic Capacitor	100 nF	63V
C66	Electrolytic. Vert. Capacitor	10 uF	35V
C67	Ceramic Capacitor	100 nF	63V
C68	Electrolytic. Vert. Capacitor	1000 uF	40V
C69	Mylar Capacitor	100 nF	63V
C70	Electrolytic. Vert. Capacitor	10 uF	35V
C71	Electrolytic. Vert. Capacitor	100 uF	35V
C72	Ceramic Capacitor	4.7 nF	50V
C73	Electrolytic. Vert. Capacitor	10 uF	35V
C74	Electrolytic. Vert. Capacitor	470 uF	40V
C75	Ceramic Capacitor	4.7 nF	50V
C76	Electrolytic. Vert. Capacitor	10 uF	35V
C77	Electrolytic. Vert. Capacitor	470 uF	40V
C78	Ceramic Capacitor	4.7 nF	50V
C79	Electrolytic. Vert. Capacitor	10 uF	35V
C80	Electrolytic. Vert. Capacitor	470 uF	40V
C81, C82	Electrolytic. Vert. Capacitor	10 uF	35V
C83	Electrolytic. Axial Capacitor	2200 uF	63V
C84	Ceramic Capacitor	4.7 nF	2KV
C85, C86	Electrolytic. Vert. Capacitor	10 uF	35V
C87	Electrolytic. Vert. Capacitor	1000 uF	40V
C88	Ceramic Capacitor	4.7 nF	50V
C89, C90, C91	Electrolytic. Vert. Capacitor	10 uF	35V
C92	Electrolytic. Axial Capacitor	2200 uF	63V
C93	Ceramic Capacitor	4.7 nF	2KV
C94, C95	Electrolytic. Vert. Capacitor	10 uF	35V
C96	Electrolytic. Vert. Capacitor	1000 uF	40V
C97	Ceramic Capacitor	4.7 nF	50V
C98 - C102	Electrolytic Vert. Capacitor	10 uF	35V
C103	Tantalum Capacitor	10 uF	35V
C104	Electrolytic. Vert. Capacitor	47 uF	35V
C105	Mylar Capacitor	470 nF	63V
C106	Mylar Capacitor	47 nF	63V
C107	Mylar Capacitor	10 nF	63V
C108	Mylar Capacitor	4.7 nF	63V
C109	Mylar Capacitor	470 nF	63V
C111	Electrolytic. Vert. Capacitor	10 uF	35V
C112	Electrolytic. Vert. Capacitor	470 uF	40V
C113	Ceramic Capacitor	4.7 nF	2KV
C114	Ceramic Capacitor	100 nF	63V
C115 - C119	Electrolytic. Vert. Capacitor	10 uF	35V
C120 - C123	Ceramic Capacitor	4.7 nF	50V

C124	Electrolytic. Vert. Capacitor	100 uF	35V
C125	Ceramic Capacitor	4.7 nF	50V
C127	Mylar Capacitor	100 nF	63V
C128	Electrolytic. Vert. Capacitor	10 uF	35V
C129	Mylar Capacitor	470 nF	63V
C132	Electrolytic. Vert. Capacitor	10 uF	35V
C133 - C138	Ceramic Capacitor	100 nF	63V
C140, C141	Ceramic Capacitor	100 nF	63V
C150	Ceramic Capacitor	4.7 nF	2KV
C151	Electrolytic. Vert. Capacitor	10 uF	35V
D1 - D37	Diode type 1N4148		
D38	Diode type 1N4007		
D39, D40	Diode type 1N4148		
D41 - D47	Diode type 1N4007		
D48	Diode type BY255		
D49, D50, D51	Diode type 1N4007		
D52 - D56	Diode type 1N4148		
D57, D58	Diode type 1N4007		
D59, D60, D61	Diode type 1N4148		
D70, D71	Diode type 1N4007		
DL1 - DL9	Led red 3 mm.		
DZ1	I.C. type LM336	2.5 V	
DZ2 - DZ5	Zener Diode	9.1 V	0.5 W
DZ7, DZ10	Zener Diode	5.1 V	0.5 W
T1	Transistor type BC337		
T2	Transistor type 2N2905		
IC1, IC2	I.C. type LM308 + Socket 8 pin		
IC3, IC4, IC5, IC6	I.C. type TL074 + Socket 14 pin		
IC7	I.C. type ULN2804 + Socket 18 pin		
IC8, IC9	I.C. type CD4093 + Socket 14 pin		
IC10	I.C. type CD4029 + Socket 16 pin		
IC11	I.C. type CD4511 + Socket 16 pin		
IC12	I.C. type ULN2804 + Socket 18 pin		
IC13	I.C. type CD4042 + Socket 16 pin		
IC14	I.C. type ULN2804 + Socket 18 pin		
IC15	I.C. type CD4060 + Socket 16 pin		
IC16	I.C. type TL074 + Socket 14 pin		
IC17	I.C. type AD536		
IC18	Opto I.C. type 4N35 + Socket 6 pin		
IC19	I.C. type TCA965		

	+ Socket 14 pin		
IC20	I.C. type TCA785 + Socket 16 pin		
IC21	I.C. type NE555 + Socket 8 pin		
IC22	I.C. type LM317		
IC23	I.C. type LM7912 case TO220 + Heat-sink 21C / W		
IC24	I.C. type LM7812 case TO3 + Heat-sink 7.7 C / W		
IC25	I.C. type LM7912 case TO220 + Heat-sink 21C / W		
J1 -J5	Jumper 2 pin		
RL1, RL2, RL3	Relay	*	
CN1, CN2, CN3	ANSLEY connector 2x10 pin		
CN4	AMP connector 4 pin 90 deg.		
CN5	ANSLEY connector 2x10 pin		
CN6	PHOENIX connector 7 pin 90 deg.		
CN7	ANSLEY connector 2x20 pin		
CN8	PHOENIX connector 8 pin 90 deg.		
CN10	AMP connector 4 pin 90 deg.		
CN11	PHOENIX connector 8 pin 90 deg.		

E20128 - SCR board

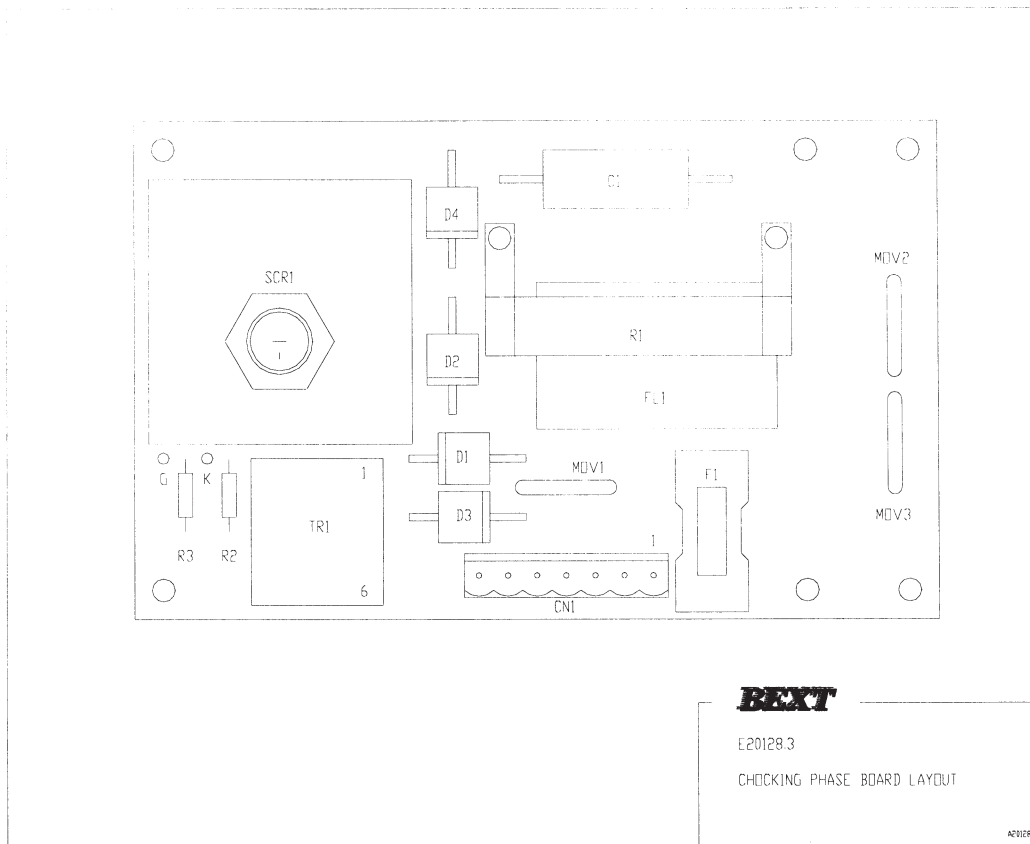

Part List of E20128 Board

Rif.	Description	Value	Remarks
PCB	Board code 2PCB0162		
R1	Resistor 10 x 64	50 ohm	5%
R2	Resistor	1 Kohm	0.25 W 1%
R3	Resistor	49.9 ohm	0.25 W 1%
C1	Axial Electr. Capacitor	0.1 uF	1000 V 5%
MOV1 - MOV3	MOV type S20K-275		
D1 - D4	Diode type P600G		
SCR1	SCR type R16RIA120 + Heat-sink 7.7 C / W		
TR1	Transformer type TI 153		
F1	Fuse + fuse holder	6,3A	250V
FL1	Arcotronics filter type FAH. AV.3100.ZF		
CN1	PHOENIX connector 7 pin		

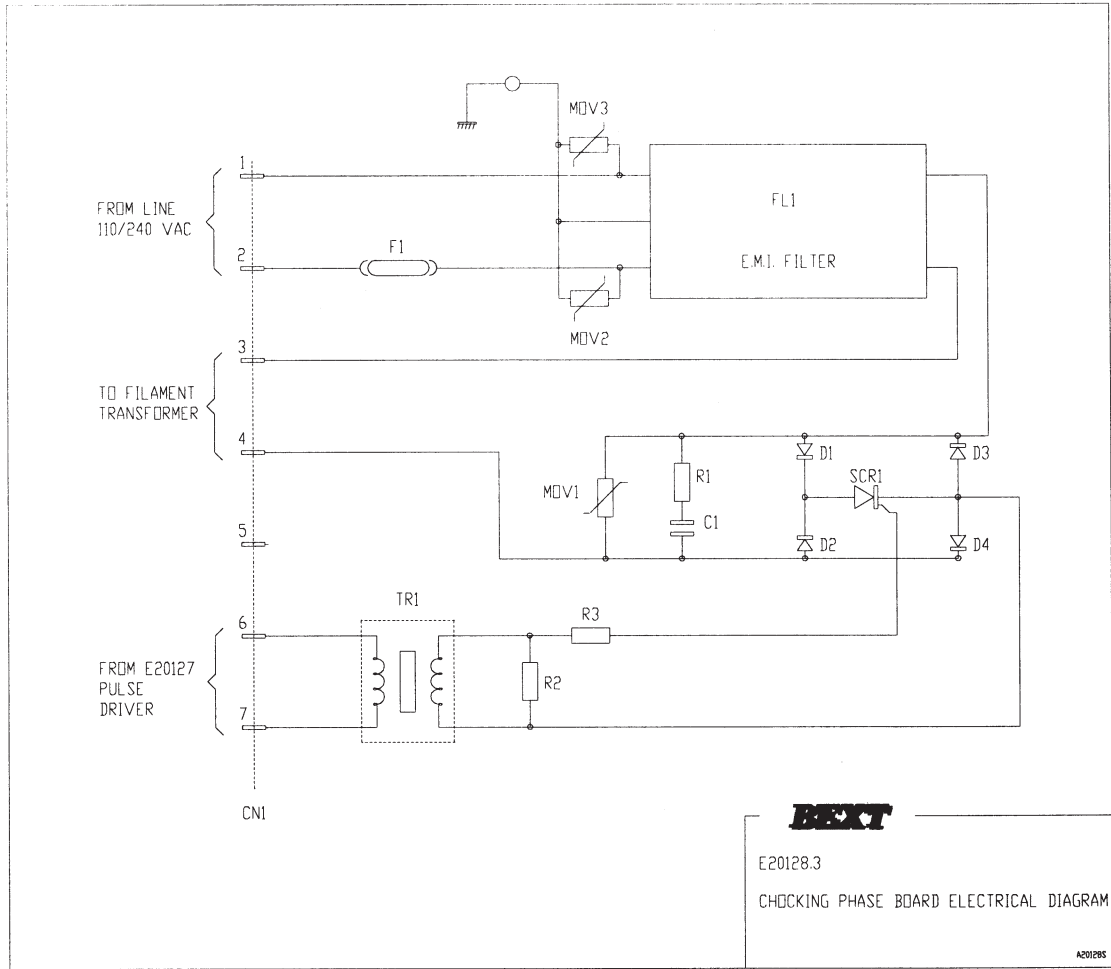

BEST
 E20128.3
 CHECKING PHASE BOARD ELECTRICAL DIAGRAM
 A20128S

E20129 - Output power measurement board

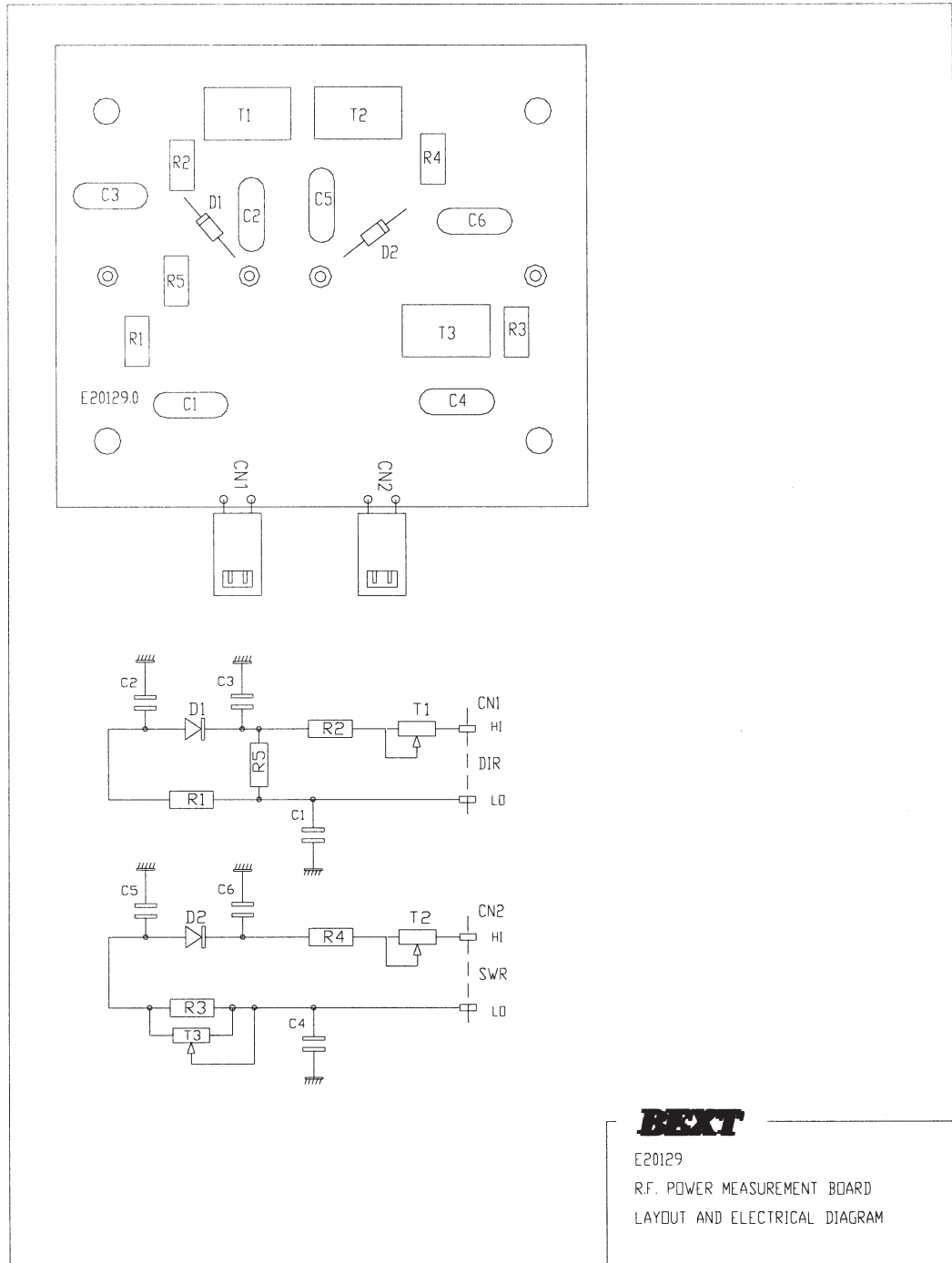

PART LIST of R.F. POWER MEASUREMENT BOARD

Rif.	Description	Value	Remarks
PCB	Board code 2PCB0163		
R1	Resistor	120Ω	1/4W 1%
R2	Resistor	1KΩ	1/4W 1%
R3	Resistor	120Ω	1/4W 1%
R4	Resistor	1KΩ	1/4W 1%
R5	Resistor	8.2KΩ	1/4W 1%
T1, T2	Trimmer type 72X	50KΩ	
T3	Trimmer type 72X	500Ω	
C1	Ceramic Capacitor step 5mm	4n7	50V
C2	Ceramic Capacitor step 5mm	18pF	50V
C3, C4	Ceramic Capacitor step 5mm	4n7	50V
C5	Ceramic Capacitor step 5mm	18pF	50V
D1, D2	Germanium Diode type AA118		
CN1, CN2	Male connector AMP MODU 2.54 2 PINS straight		

E20130 - Three phase rectifier board

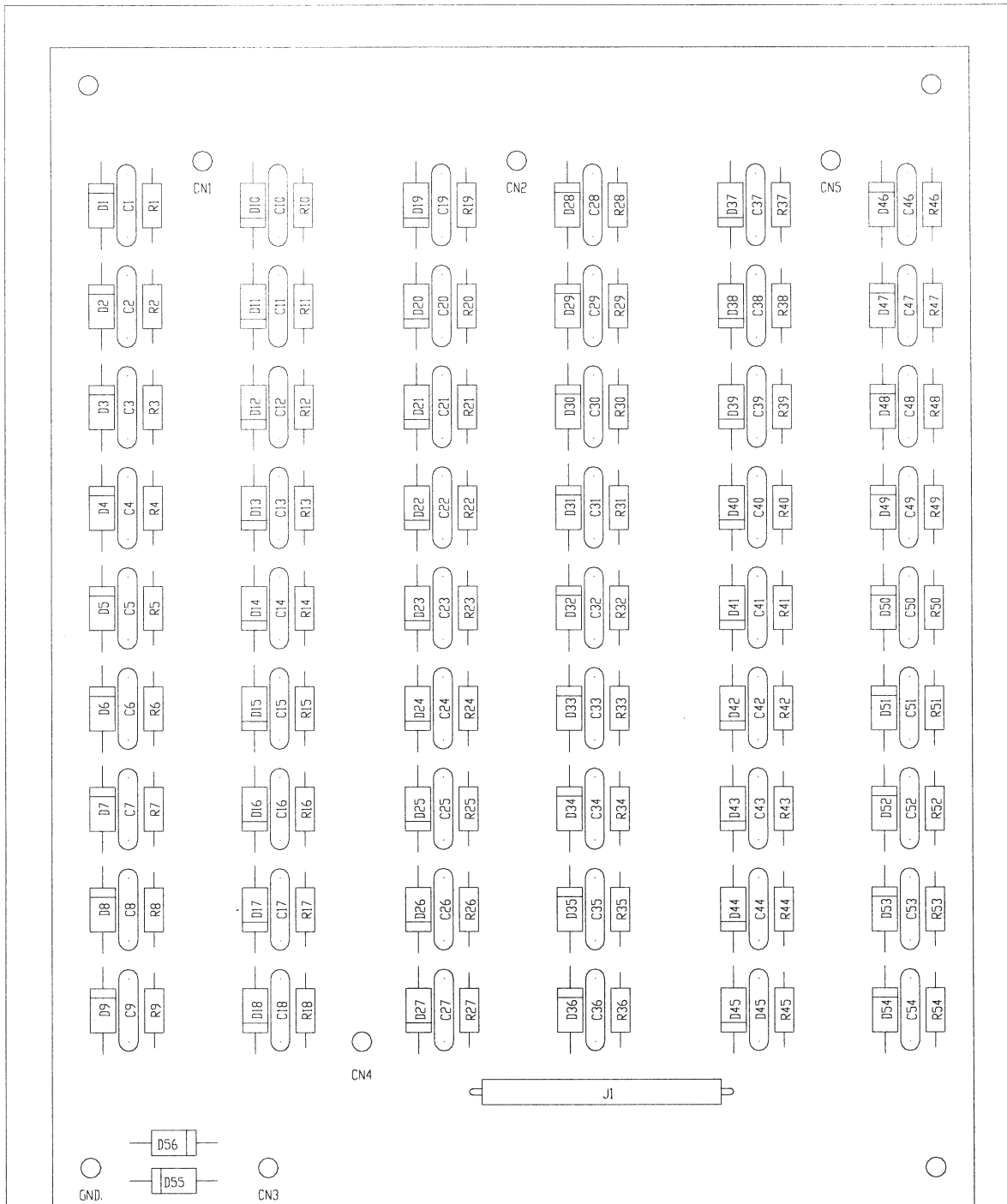

E20130
HIGH VOLTAGE RECTIFIER BOARD
LAYOUT

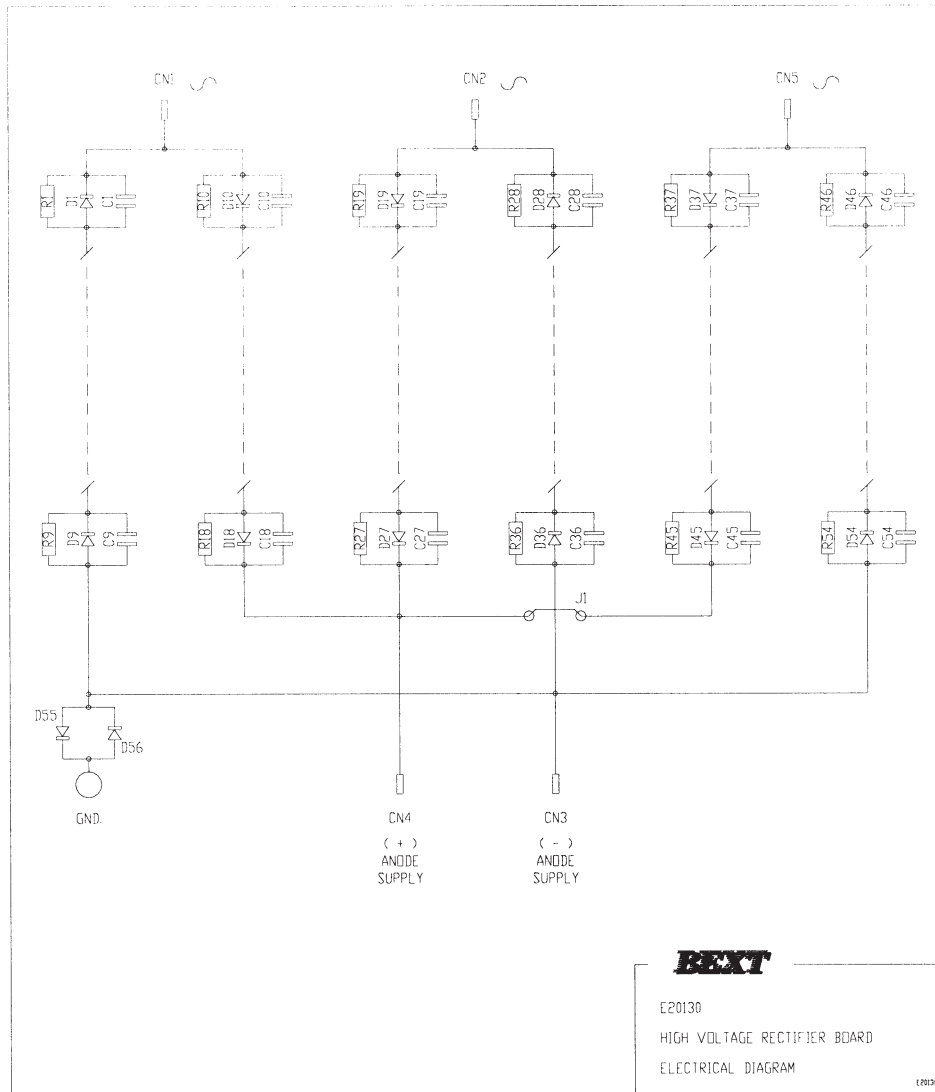

Part List of E20130.0 Board

Rif.	Description	Value	Remarks
PCB	Board code		
R1 - R54	Resistor	220K+220K	0.5W 5%
C1 - C54	Ceramic Capacitor	4700 pF	2 KV
D1 -D56	Diode type BY255		
CN1 - CN5	Male faston for PCB + Clamping screw 4 mm.		
J1	Wire length 4cm.	4 cm	

E20137 - Single phase rectifier board

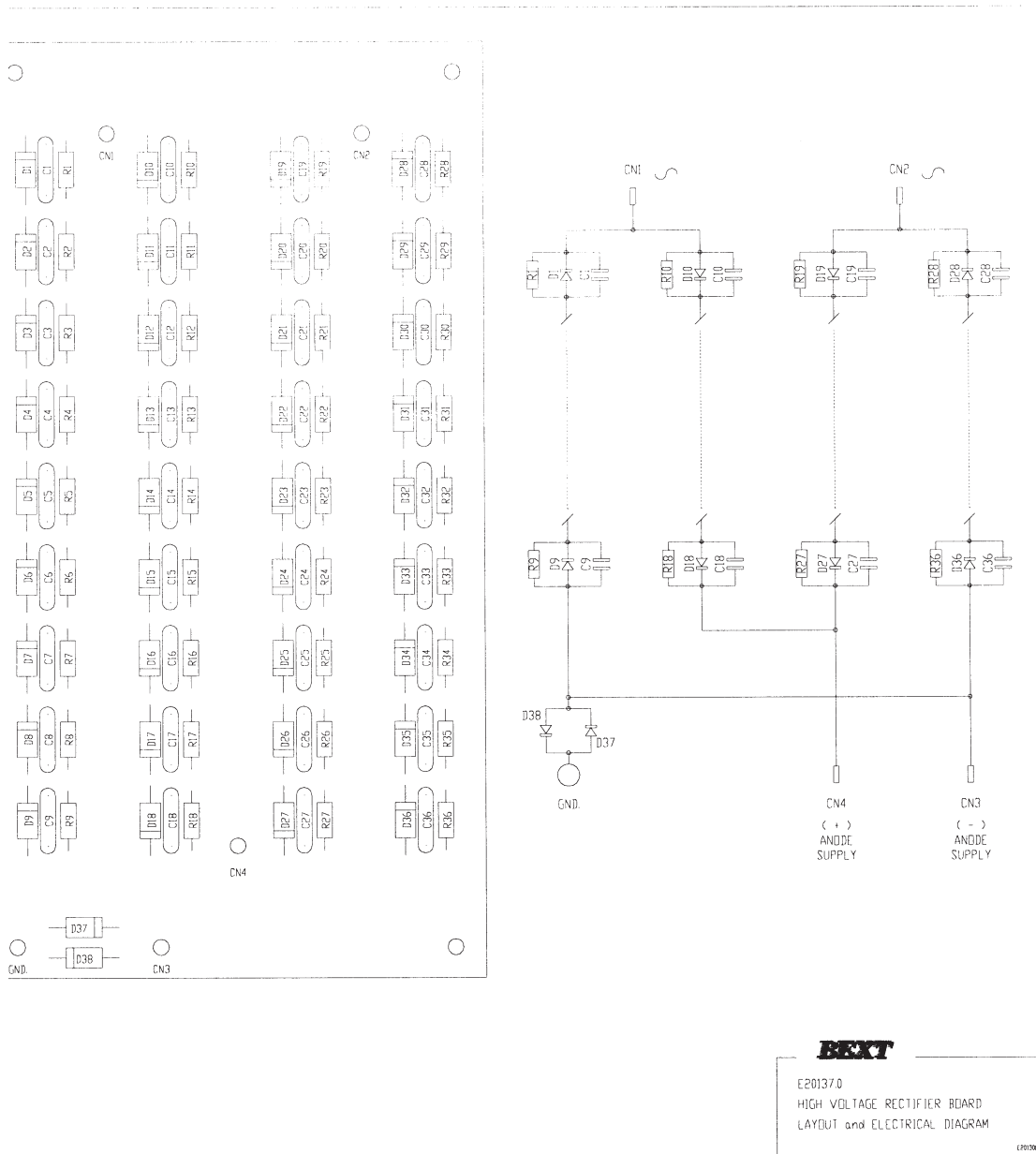

Part List of E20137.0 Board

Rif.	Description	Value	Remarks
PCB	Board code 2PCB0164		
R1 - R36	Resistor	220K+220K	0.5W 5%
C1 - C36	Ceramic Capacitor	4700 pF	2 KV
D1 - D38	Diode type BY255		
CN1 - CN4	Male Faston for PCB + Clamping screw 4 mm.		

E20138 - Voltage divider board

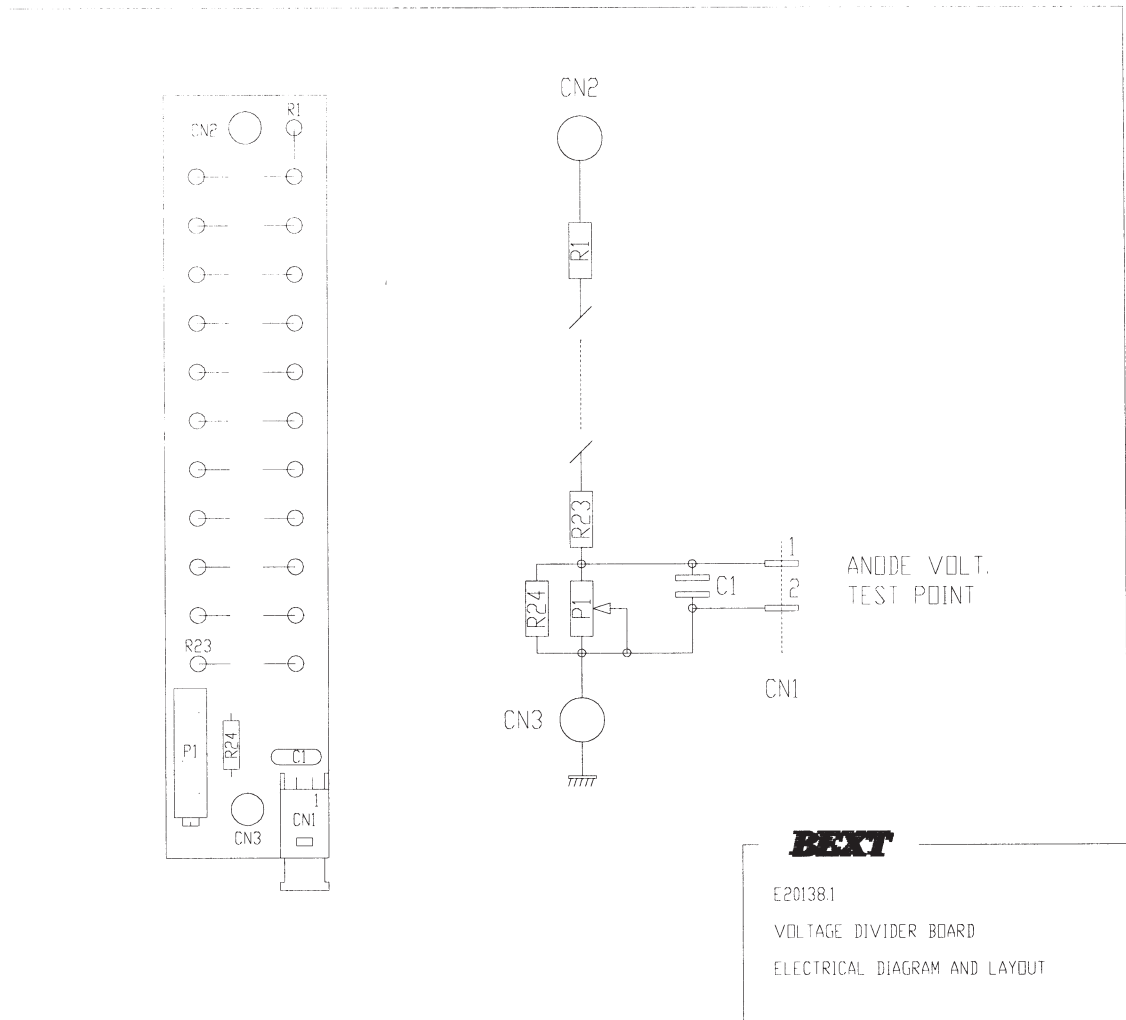

Part List of E20138.1 Board

Rif.	Description	Value	Remarks
PCB	Board Code 2PCB0176		
R1 - R23	Resistor	2.2 M	0.25 W 5%
R24	Resistor	100 K	0.25 W 1%
P1	Trimmer type 89P	200K	
C1	Ceramic Capacitor	100 nF	63V
CN1	AMP connector MODU male 2 pin angled		
CN2, CN3	Fixing Stud		

E20139 - Interface board (optional)

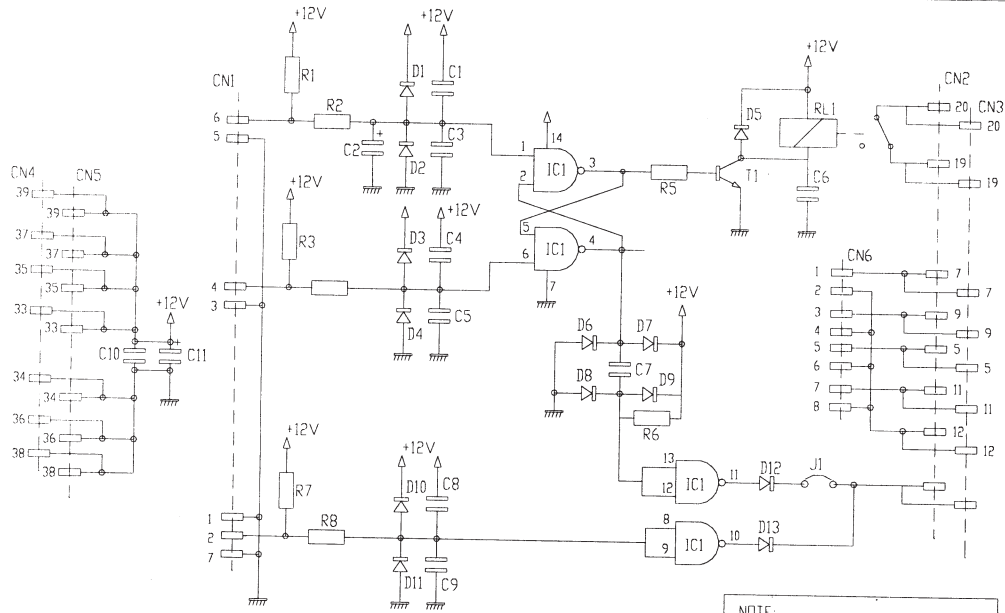

NOTE:
Connectors CN2 with CN3
and CN4 with CN5 are
paralleled pin to pin

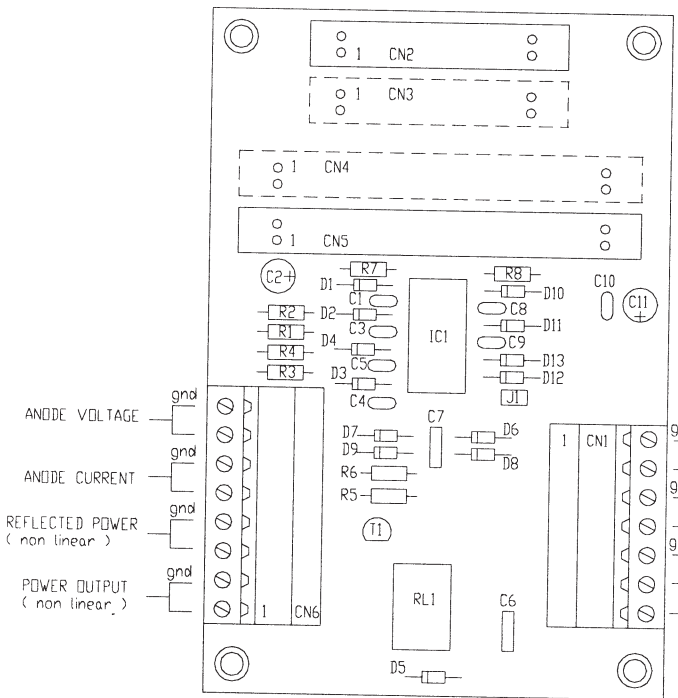

NOTE:
When the jumper is in place, the
interrupts will recycle in auto mode

A contact closure of 50 ms duration
will reset the interrupt counter
A contact closure of 50 ms duration
will place amplifier in stand-by
A contact closure of 50 ms duration
will place amplifier in operate
gnd to external equipment

NOTE:
CN3 and CN4 are mounted
on solder side

BEST
E20139.1 - INTERFACE BOARD
ELECTRICAL DIAGRAM

Part List of E20139.1 Board

Rif.	Description	Value	Remarks
PCB	Board Code 2PCB0177		
R1 - R8	Resistor	10K	0.25 W 1%
C1	Ceramic Capacitor 5mm	4.7 nF	50V
C2	Electrolytic vert. Capacitor	10 uF	35V
C3,C4,C5	Ceramic Capacitor 5mm	4.7 nF	50V
C6, C7	Mylar capacitor 5mm	100 nF	63V
C8,C9,C10	Ceramic Capacitor 5mm	4.7 nF	50V
C11	Electrolytic vert. capacitor	10 uF	35V
D1 - D4	Diode type 1N4148		
D5	Diode type 1N4007		
D6 - D13	Diode type 1N4148		
T1	Transistor type BC547		
IC1	IC type 4093 + socket 14 pin		
RL1	Relay SIEMENS V23101 D0106 B201		
J1	Jumper		
CN1	PHOENIX conn. 7 pin angled		
CN2, CN3	ANSLEY conn. 10+10 pin male with extractors		
CN4, CN5	ANSLEY conn. 20+20 pin male with extractors		
CN6	PHOENIX conn. 8 pin male with extractors		